

WEI

VIENNA,
AUSTRIA,
APRIL 17-19,
2018

2018 WEI
INTERNATIONAL
ACADEMIC
CONFERENCE PROCEEDINGS

BY THE WEI **EDUCATION & HUMANITIES**
ISSN 2167-3179 (ONLINE) USA

Table of Contents

Climate Change in the Lake Chad Basin and the Boko Haram Security Challenges in Northern Nigeria	3
ABDULLAHI M. ASHAFA	3
Families with handicapped children: A qualitative research on Parents' experience regarding their (other) normally developed children	52
ASNAT DOR AMANI SHIBLI	52
Qualitative Examination of the Perspectives of Parents with Gifted Children on Mathematics Education	54
AVNI YILDIZ	54
Evolution of the political status of female rulers in England in the X-XI centuries	64
ANNA GOROKHOVA	64
Early Childhood Education Teachers' Recommendations for Effective Professional Development Practices	72
GOZDE ERTURK KARA	72
E-Tests: Pros and Cons Experimental Study on Engineering Students in Jordan	74
HASAN SHALABI	74
Political Impact of Public Policy as an Academic Discipline in New Democracies: Case Study the Republic of Macedonia	86
HRISTINA RUNCEVA TASEV	86
Visualize This: A Visual Rhetoric Exercise for STEM Students	90
JOSEPH WILLIAMS	90
The Burgeoning of Tutoring Cram Schools in Taiwan As Seen from a Durkheimian Sociological Perspective	91
L.L.KUO	91
Some Aramaic Inscriptions in Georgia	92
MARIKA CHACHIBAIA	92
Architecture for Personalized Academic Feedback	94
ANNETTE VAN DER MERWE	94
The Reality of placement of the Strategic Adaptation programs by Kuwait University Leaders for Crisis Management during the Environment Uncertainly	112

MEZNAH SAAD ALAZMI	112
The Institutionalization of the Political Science in the Republic of Macedonia	114
MILENA APOSTOLOVSKA-STEPANOSKA	114
Arab-West International Relations: Jürgen habermas to Balance Future Western Foreign Policies Towards the Mena Region	129
MOHAMMAD AHMAD HASAN AL-JARARWAH	129
The first part of an investigation of Greek students' use of study skills within the learning context of an English for Specific Academic Purposes course	131
OURANIA KATSARA	131
The United States and British Southeast Asian Policy 1950 – 1955	157
SAH-HADIYATAN ISMAIL	157
Qualitative Examination of the Perspectives of Parents with Gifted Children on Mathematics Education	158
SERDAL BALTACI	158
Web-Based Systems For Supporting Chronic Disease Self-Management	170
TEODORA DIMCHEVA	170
Methodological Problems Detected in Turkish Dialectical Studies	171
TUĞBA AYDIN YILDIZ	171
Students' Satisfaction with E-services at Jerash University	178
YOUSEF ALJARAIDEH	178
Analysis of The Evaluation of Mentors and Students of The Pharmacy Faculty In The City of Plovdiv (Bulgaria) For The Pre-Training In Pharmacy	192
ZHIVKO PEYCHEV	192

CLIMATE CHANGE IN THE LAKE CHAD BASIN AND THE BOKO HARAM SECURITY CHALLENGES IN NORTHERN NIGERIA

ABDULLAHI M. ASHAFU

PhD, Department of History, Kaduna State University, Tafawa Balewa Way, Kaduna-Nigeria

ABSTRACT

The Chad Basin, which is the largest closed drainage basin in Africa, has for quite some time being at risk of the adverse effects of climate change, including climate variability and extremes that the culturally varied population in the area are unable to cope with. At a point, the Lake Chad region had vast expanses of arable and grazing land with rich fish stocks that made it an economically and environmentally important area for Chad, Nigeria, Niger, Cameroon, and the Central African Republic. Because climate change hinders this economic viability, it also exposes the communities in the Lake Chad region to the Boko Haram insurgency in northern Nigeria, thereby becoming vulnerable and leaving with great humanitarian crisis, if not disaster. The Boko Haram insurgency, which broke out in 2009 in Nigeria's north-eastern state of Borno, had gradually spread to other States in the Nigeria. Its horrific military attacks on civilians resulted in mass killings, abductions and destruction. This was to spread into three other countries: Cameroon, Chad and Niger Republic and later developed a violent confrontation by engaging the security forces of the sub-region in the form of Multinational Joint Task Force. This paper espouses not only how climate change factored in the socio-economic decay that fed the Boko Haram insurgency in Nigeria, but also how the communities were exposed to the vagaries of both ecological catastrophe and devastating insurgency of out of proportional magnitude, leading to counterinsurgency operations by both the Nigerian military and other security and vigilante outfits. It argues about the nexus between climate change, poverty and insecurity in an African setting.

Keywords: Boko Haram, Climate Change, Lake Chad Basin, Terrorism, Insurgency, Counterinsurgency

Introduction

Boko Haram in Nigeria is a terrorist organization that calls itself as Jama'atu Ahlis Sunnah Liddawa'ati wal Jihad (people committed to the Prophet's teaching and jihad). Is one of the deadliest extremist armed groups in the world (Global Terrorist Index 2015). The name Boko Haram is derived from a Hausa term that means western education is forbidden to suggest its anti-West posture. It started as a fanatical movement by a group of an Islamic sect in Damaturu, Yobe State and later moved to Maiduguri, Borno State in the Nigeria's North-East Region that served as the base for the movement. The nucleus of its leadership of Boko Haram had been in Maiduguri for a long time, being the administrative capital of the defunct North-Eastern State (1967-1975) and now Borno State (1975-date even after Yobe State was created out of the then larger Borno State). Like its fanatical Maitatsine precursor during Nigeria's Second Republic (1979-1983), which had to be crushed by military force, Boko Haram emerged as a weird ideological Islamic movement. Such movement and activities were in complete disregard of Nigeria's constitutionally sanctioned secularity, when it wanted to impose, even by all means, a kind of Islam on the Nigerian State and its plural religious communities. It is important to say ab initio that matters of religion in Nigeria are highly sensitive and mostly in contestation across all levels of governance and inter-group nexus.

Boko Haram emerged at a time the dust; if not the serious bloody crisis arising from the introduction of Shari'ah legal system in some northern States of the country had not been doused. The uprising or what many may refer to as the Boko Haram insurgency had within a short period transformed into an open terrorism. Its horrific military attacks on civilian soft targets resulting in mass killings, the destruction that affected both rural and urban settlements, the unprecedented displacement of large population both as refugees and Internally Displaced Persons, the abductions of school girls and rural women (mostly as sex slaves) and the trauma it brought to communities, the destruction of urban infrastructure, rural economy and the resultant widespread insecurity, as well as much more havoc that it caused could only be compared to the Nigerian Civil War of 1967-1970. This sad story was to spread into three other neighbouring countries, viz: Cameroon, Chad and Niger Republics and later developed a violent confrontation that required the formation of sub-regional military group to contend the situation known as the Multinational Joint Task Force made up of forces from Nigeria, Cameroon, Chad and Niger.

For a movement that started ostensibly for religious revival that later transformed into insurgency by ragtag soldiers supported by sophisticated war machines, and daring into a sub-regional terror group aligning itself with known terror organizations in the world was a clear threat to Nigeria and the states around the Lake Chad Area. More daring by the Boko Haram was the feeling that it could successfully engaged the forces modern states in a military dwell for whatever cause, needs to be interrogated intellectually. The spread and swiftness of the Boko Haram military engagement of the Nigerian military and later the Multinational Joint Task Force for almost a decade, says much about the capacity of terror groups to rundown modern states or the inability of modern states to swiftly and successfully tackle the challenge of terrorism.

While we cannot discountenanced the fact that the failure of the Nigerian state must have created the breeding ground that fertilized the what brought up the Boko Haram movement and the subsequent mishandling of it which, which transformed it into a terror group, the climate change and the environmental impact in creating poverty with little or no alternative towards livelihood has remain a major factor in the Boko Haram outbreak and its sustainability as a terror organization. This is an issue security experts and the intelligence community in the Sahel have not seriously interrogated to find the linkage. This paper seeks to fill in the vacuum by relating the Boko Haram phenomenon to the climate change in the Lake Chad Basin Area.

The paper espouses not only how climate change factored in the socio-economic decay that fed the Boko Haram insurgency in Nigeria, but also how the communities were exposed to the vagaries of both ecological catastrophe and devastating insurgency of out of proportional magnitude, leading to counterinsurgency operations by both the Nigerian military and other security and vigilante outfits. It argues about the nexus between climate change, poverty and insecurity in an African setting. It argues that the extreme poverty in the Lake Chad Basin area could be linked to the devastating climate change, but again factored by decades of poor governance, which in Nigeria's democratic context had produced weak state legitimacy and other governance -related grievances that Boko Haram exploited to successfully recruit thousands of disillusioned youths as fighters. It is made in five structures, with the introduction being the first. The second describes the climate change in the Lake Chad Basin; the third relates this climate change that disillusioned youth to be enticed into the Boko Haram; the fourth discusses the security challenges that became of Boko Haram and the counterinsurgency. The conclusion is the last.

A Cursory Analysis of the Origin of the Boko Haram

The historicity of Boko Haram, like its predecessor the Maitatsine, could be traced to the inspiration derived from the anti-colonial resistance by the Mahdist movement in the earlier 20th century when British colonial rule was being imposed on the northern Nigerian area, represented by the defunct Sokoto Caliphate. Though this resistance continued up to the 1960s when Nigeria got its political independence (Saeed 1992), the Constitutional Review Committee formed by the Military Government as a process of transition to civil rule between 1977-1978 was to ignite what became the Shariah debacle, when some Muslim delegates to the Conference insisted on the establishment of a Sharia Court of Appeal for the Muslims, the Christians vehemently opposed to the idea. Though the matter was handled with maturity, it was an incident that for the first time in Nigeria brought religious friction at the level of governance between Muslims and Christians. The success of the 1979 Iranian revolution swayed many youths in northern Nigeria into the formation of revivalist Islamic movements in making Islam a major factor in Nigeria's affairs. This was also at the time the Maitatsine scourge erupted. Many University students and other tertiary institutions in northern Nigeria got involved in the Iranian-Shiite induced ideology of resisting Western life style and culture, which was a model amongst the educated and ruling elite, which has been documented by several authors (Usman, 1987; Lubeck, 1987; Williams 1997).

It appears that throughout military regimes, except some ethnic crisis, which were given religious coloration, conflicts in Nigeria factored by religion were mostly under democratic regimes. The launching of the Sharia in Zamfara State in 2000, few months after the return of democracy in Nigeria, as part of the Islamic revivalist movement, triggered yet another wave of crisis. By 2003, the clamour for the Sharia, which many associated with the glaring failure by the political class to make life better in a democratic dispensation, sent shiver to many of the State Governors who variously but surreptitiously announced the adoption of Sharia, but which implementation many youths regarded as insincere and illogical. All this provided precedence for the Boko Haram, which as so-called reformist movement interested in the implementation of Sharia and if need be replacing the national constitution had engaged in protestation regarding some local grievances that snowballed into a highly sophisticated terror group that became known for its capacity to inflict destruction to the Nigerian state and neighbouring countries

(Kyari 2017). Boko Haram leaders at certain stage of their activities identified with the Shiite movement had seized the opportunity of the widespread global terrorism to align itself with the Salafist doctrine and becoming a unit of the group in West Africa.

The overzealousness of the leadership ushered in the unorthodox and weird views about Islam and society. It came to the open when it was said that under the influence of Muhammad Yusuf, many school graduates who could not find employment and living in penury, where living side by side with the political class who were dazzling in superfluous affluence by virtue of holding government positions and in control of public funds tore their certificates to join a movement that identified such state of affairs to the western mentality of the political elite. Already, acquisition of western education has been one of the basic requirements for entrance into public service and therefore access to massive state resource, mostly acquired by corruptly. This was the basis for the group's condemnation of western education (known in Hausa as Boko) and its subsequent labeling as haram (forbidden). This anti-western education was to define the group and its identity viz: Boko Haram. Mohammed Kyari, captures it vividly when he noted that allowing Yusuf to preach freely and in the open whose messages were on anti-corruption and bad governance targeted at the political, social and economic situation many people were not happy with, especially the kleptomaniac attitude of the Borno State Governor, Ali Modu Sheriff, which attracted large followers (Kyari, 2017).

Of recent, Boko Haram at least remains as the famous manifestation of Salafism in northern Nigeria. Mainstream Nigerian Salafis often use strident and confrontational rhetoric toward other Muslims and toward Nigerian Christians. However, John Campbell was of the opinion that Salafist are largely not jihadists; they do not generally engage in violence; they do not advocate the overthrow of the secular state; and they do not reject Western-style educational institutions from which Boko Haram derived its name (Campbell 2017). Therefore, while majority of Nigerian Muslims are Sunni, the Salafists are Sunni Muslims too whose approach to Islam however involves a literalist creed and a conviction that every issue in contemporary human life can be resolved by consulting and exceptionally applying the Qur'an, the Sunnah (model or tradition) of the Prophet Muhammad, and the example of the first three generations of Muslims (the salaf). No wonder, Salafis are hostile to the Shiite Islam and Sufism (a mystical approach to Islam), and to various theological sects that seems to place emphasis on the Sunnah. For this reason, Salafis or Salafism represents the pristine Islam of the early community. A minority, albeit deadly and highly visible minorities amongst the Salafis are called "Salafi-jihadis," who

embrace jihadism and try to impose Salafism by force, for which reason, Boko Haram (for self-proclaiming an Islamic State in a secular and multi-religious nation), is a Salafi-jihadist movement just like al-Qaeda, AQIM and its affiliates, Ansarul Islam and Jama'atul Nasril Islam Wal Musulumin (Mali), Ansarul Shariah (Libya), Shabab al-Tawheed (Tunisia), Ansar Baitil Maqdis (Egypt) and so on.

Mohammed Yusuf was a student of Sheikh Ja'afar Mahmud Adam, famous Kano-based Salafist scholar in Nigeria. At a point, the latter had to disown Yusuf for his fanatical and weird views about Islam, his misrepresentation of jihad and unfounded anti-western education in an under-developed part of Nigeria lagging behind in modernity at a time which it needed catching up with particularly the southern part in terms of the progress made in western education. After the assassination of Sheikh Ja'afar Adam in 2007, his former student, Muhammed Yusuf, who was also a local demagogue, upgraded his jihadist mentality, citing the collapse of the social fabric, political shenanigan among Nigerian leaders as well as the harsh economic conditions to preach harshly against political and economic corruption and bad governance that appealed to the young ones looking for alternatives messaging about their bad conditions, especially when he called for the implementation of Islamic Shari'ah. Already, many of those who flocked around Muhammed Yusuf were an illiterate mop both in Islamic sciences and Western education that they easily became gullible and hoodwinked by Yusuf's demagoguery of what many Muslim scholars, including the Chief Imam of Maiduguri alleged to have been supposedly assumed to be based on Islam (Ashafa, 2017: 248)

Brenner (1992) has argued, and is agreeable that the old Borno Empire from which Islam came to northern Nigeria between the 11th and 15th centuries has been multi-ethnic and ideologically conservative. Borno had a history of tolerant Islam with no history of religious fanaticism like the Sokoto revolutionary Islam that resulted into the 19th century Jihad. In this case, though the collapse of social and family values in Borno, which was reinvigorated by its loss of its historic centre of Islamic fluorescence, the climate change and the economic hardship and other form of exigencies it brought about combined to thrived the idea that also brought Boko Haram, whose army, derived from frustrated youth around the Lake Chad Basin sustained the movement's fighting force and its destructive activities with impunity. Appreciating this requires understanding of the Lake Chad Basin Area as a starting point.

Understanding the Lake Chad Basin

The Chad Basin, which refers to areas of Nigeria, Chad, Cameroon and Niger Republics, is the largest closed drainage basin in Africa. For quite some time it has been at risk of the adverse effects of climate change, including climate variability and extremes that the culturally varied population in the area were unable to cope with. At a point, the Lake Chad region had vast expanses of arable and grazing land with rich fish stocks that made it an economically and environmentally important area for the over 30 million population in countries bordering the Basin: Chad, Nigeria, Niger, Cameroon, and the Central African Republic. Because climate change hinders this economic viability, and affected livelihoods, it also exposed the communities in the Lake Chad region to the Boko Haram insurgency in Northern Nigeria, thereby becoming more vulnerable to security challenges that go with great humanitarian crisis, if not disaster.

The Lake Chad is located in the Sahel region of Africa between (lat. 12:30 N to 14:30 N and long. 13:00E to 15: 30E). It is one of the world's largest and most historical Lake in the region. The Lake Chad Basin, which is shared by Algeria, Cameroon and the Central African Republic, Chad, South Niger, Nigeria, and the Sudan. By this and with a population estimated at 40 million inhabitants according to statistics of 2010, it is a large entity representing about 8% of the total size of the African continent. The Lake Chad Basin is an essential water resource for primary livelihood activity such as farming, fishing and pastoralism that provided basic livelihoods for fishermen, livestock herders and crop farmers groups of the riparian countries, most of them among the poorest in the world. It is one of the most vulnerable regions to climate change bordering North-Western Cameroon and the Central African Republic, South Western Chad and South-Eastern Niger Republics, and North-Eastern Nigeria. The climate variation resulting into degrading socio-economic condition in the Lake Chad Basin area, coupled with increased insurgency in the area has made the Lake a policy concern for riparian governments (Okpara, et al, 2016).

In the 1940s, the size of the Lake Chad was said to be between 25,000-26, 000 km square and presently it is said to be about 2800 km square, which made it the world's sixth largest inland water body (LCBC 2014). The climate change, which resulted in the speedy drying of the Feeder Rivers supplying over 90 % of the Lake water, has forced communities living along the courses or banks of the Feeder Rivers to block supply in to the Lake in an attempt to cope with the climate change resulting in the massive reduction of the size of the Lake. By this, the Lake Chad

today “a shriveled, fragmented collection of two distinct water bodies, the northern and southern pools, dotting a drought-prone, desiccated landscape within the arid and semi-arid Sahel corridor” (Okpara, 2016: 782). Worse still is the fact that the abundant resources the Lake was hitherto known for and on which fishermen, herders and farmers depended on are no longer available. In relation to the increasing desertification of the Sahara, incessant hunting of the few scattered trees serving as a shelter belt between the Sahara desert located in the north of the Sahel region and the fertile Lands for wood fuel that boosted the firewood business has devastating effect on the Sahel, resulting in job losses among other poverty indicators.

With evident lake drying shaping livelihood drawbacks and opportunities, the locally evolved responses, which have remained reactive (to cope with and adjust to shocks or stresses/adverse conditions), rather than proactive (to search for and create livelihood options and strategies in order to increase competence with which to confront a threat) despite the assistance by governments and development partners, have not been enhancing livelihoods meaningfully. With limited opportunities outside subsistence agriculture, there was also the influx of mixed ethnic migrants competing for little available resources that also goes with increasing spate of violence all combined to enhance livelihood challenges.

There is direct bearing between the drying of the lake and livelihood. Already, while resource users lose or gain under conditions of water resource depletion, water-limited environments are increasingly a global focus of resource conflict concerns especially that the lake drying interacts with local contextual issues (White, 2013).

While the Lake Chad Basin area suffers decadal rainfall variability, increased population and irrigation activities among other changing agricultural practices, a United Nations Human Development Report (2015) has indicated that the lakeshore dwellers are poverty stricken, much as the location itself has a relatively high poverty rate. First, the Lake Chad Basin suffer population pressure as the northern Sahel further desiccated, fluctuating rainfall that resulted in crop failure, declining income levels from annual harvests and intensified competition over limited resources. A study on Small Lake Chad areas has indicated this more succinctly:

... farmers who cultivate on the Lake beds as they regularly lose crops to floods. FGDs with farmers revealed a link between the current Lake state, water scarcity and low food production...(though) fishing activities have not decreased, there was general agreement that the size and quantity of fish catches have declined...(there was complain of) long

distance fishing, high costs of renting or acquiring boats, strict fishing rules regarding the types of gear to use, high water access charges imposed by local authorities and the intrusion of unlicensed migrants from neighbouring countries, whose better fishing expertise often deny local fishermen access to the large fish. Similarly, pastoralists complained that their livestock were often sick and many had died with the decline in the richness and quality of the SLC pasture (Opara, et al, 2016: 788-789)).

Consequently, the LCBC has observed as follows:

Current climate variability in the area is hard on the people and it is driving them into poverty; some commit crimes because it is increasingly becoming difficult for them to secure their livelihoods merely by farming or fishing or herding (LCBC 2014).

How do we appreciate the impact of the climatic variation on rural livelihoods, in relation to the Boko Haram security challenges, is what we now turn to.

Nexus between Climate Change and the Boko Haram Phenomenon

The Lake Chad basin being one of the most important agricultural heritage sites in the world, provides a lifeline to nearly 30 million people in four countries—Nigeria, Cameroon, Chad and Niger. The climate change that necessitated the shrinking of the Lake Chad has a direct or indirect bearing with the birth or success of Boko Haram in the area, itself being a terror group with devastating effects on the countries and people around the lake area. Being the fourth largest lake in Africa, the Lake Chad has over the years lost almost 90 percent of its water, in a manner that the once Africa's largest water reservoir in the Sahel region, shrunk to 2,800 square kilometers in 2014 from its 26,000 square kilometers it were in the 1960s.

The way the climate change affected livelihood has a direct repercussion in causing and exacerbating the Boko Haram conflict. While farmers, fishermen and herders were affected rather badly, as food supplies withered from drought, cows were dying and herders put out of culture, the fishes were no longer available. At the same time, governments in the area responded to the shrinking of the lake in 1989 by stopping all forms of irrigation projects in the basin since the level of the lake fell 3m below the critical level. The hardship due to poverty this generated was exploited by the leadership that created Boko Haram. With about nine million people living in the region and another thirty million depending on a crippled lake for the bare necessities of life, naturally makes the people begin to fight over the things they needed to live, thereby causing

tensions among communities around Lake Chad with repeated conflicts among nationals of different countries over control of the remaining water. By this, it means that even before the advent of Boko Haram, most people in the Lake Chad Basin have been bearing arms to help them survive the extremely harsh challenges occasioned by the climate change, and thus must have prepared them to view Boko Haram as a legitimate alternative means of survival.

In this situation, uneducated rural people who used to making a living from either farming, livestock and fishing have come to realize that these subsistence occupations have become unviable. Youths that were put out of traditional livelihood started to migrate to urban areas, with Maiduguri as the most attractive alternative. Unfortunately, Maiduguri, which seemed to be the attractive center for a better livelihood, had its own challenges: absence of modern industrial infrastructure and tight labour market, so that only some of them could find jobs. Most of the disillusioned youth became attracted to Boko Haram. But much as others turned to criminal activities, the desperate herders who were migrating with their animals engaged in disrupting life in areas they did not use to go to or where the relationship, *ceteris paribus*, were hitherto cordial.

In this connection, when the idea of a movement the type that became Boko Haram was mooted, it was born around the Lake Chad Basin. The tiny group of overzealous and religiously inspired young persons that became Boko Haram started from a rural seclusion in Kanamma on the Nigeria–Niger border in 2003. The Lake Chad area was the same area the pre-colonial Borno Empire acquired not only its Islamic heritage, but also military prowess and economic power. It was like history repeating itself. The unhindered anti-corruption, anti-government and anti-bad governance preaching of Boko Haram leaders in and around Borno at a time the climate change had evicted poor and frustrated young men into the urban area, which Maiduguri and Damaturu, the administrative capitals and economic and commercial nerve centre in the north-eastern Nigeria was to transform a fanatical movement into a notorious terror group. That it aligned with global Salafist movement at a time of widespread global terrorism also provided Boko Haram with a catalyst to violence and the means to sustain it against the Nigerian state as well as the multinational military joint task force.

Attracting ignorant, poor and desperate young people living within the fringes of the Lake Chad, an area devoid of modernity, infrastructure, presence of governance in terms of industries and welfare provided a fertile ground exploited by Boko Haram to mobilize and strike. The anti-

western and anti-democracy posture of Boko Haram as well as its clamour for the Sharia was supported by demonstrable example towards economic support and empowerment programmes to flowers to cushion the hardship of urban life and served as a means of generating little income for supporting rural families. This was in the form of purchasing motorcycles used for Achaba that characterized urban transportation in most of Nigerian cities. At a time people in government engaged in brazen corruption and open thievery of public funds, majority were wallowing in poverty, which prompted Boko Haram to adopt palliative welfare schemes the Achaba was a major aspect. The number of people engaged in the motorcycle business was overwhelming, much as their nuisance was becoming intolerable to the Borno State government. As a means to control the Boko Haram Achaba business, a major source of income to members who were also remitting proceeds to the organization, the Ali Modu Sheriff government in Borno State imposed the use of safety measure by wearing helmet. Instead of allowing the Achaba operators to procure the helmet in the open market, the government insisted it must be purchased from the State's Internal Revenue Generating Agency within a deadline.

The police, who have not been friendly with the Yusufiyya 'boys,' was eager to enforce the legislation on the use of crash helmet. The overzealousness in enforcing this rule did not go well with most Achaba operators, not excluding the Boko Haram. The purchase and use of state-imposed legislation on the use of helmet was viewed by the Boko Haram as succumbing to a legislation that had no basis in Islam that could not be found in the Qur'an and sharia. There was an uneasy relation between the Boko Haram and the police who were overzealous to deal with the movement's elements. The opportunity came when the deadline over the use of motorcycles without a helmet had lapsed over and it was time to enforce it. By July 2009, the police were happy to begin the enforcement of the legislation on the use of crash helmet and soon this led to confrontation between the police and the Boko Haram members, most of who were the violators of the legislation and who were alleged to be attacking police stations and prisons to free their arrested colleagues.

Muhammad Yusuf consequently in an aura of arrogance and in view of the manner his followers were ready to die in carrying his instructions, ordered the government through an open ultimatum to reverse the legislation within 40 days threatening heaven would be let loose, "which only Allah had the power to stop" (Murtada, 2013: 8). When 40 days lapsed, the order was for the sect members to go about their business without in violation of the crash helmet legislation. The police reacted by making arrests, which led to a violent confrontation that left some sect

members dead. issued resulting into some deaths of the members. Immediately, riots began spreading from Maiduguri to Bauchi, Kano and Yobe States. The police were mobilized to counter the riots. The riots in Maiduguri were more severe and soldiers waded in and captured Muhammad Yusuf and handed over to the police, who was subsequently killed in an extra-judicial manner, so too was a known major sponsor of the group Buji Foi. This transformed the Boko Haram into engaging in open violent attacks on police stations, schools, churches, public infrastructure and security posts (Nwanko and Falola, 2009: 2; Oyegbile and Lawal 2009: 67-71).

It has thus become common to say that:

1. The Chadian shore that links up with Nigeria's north-east, which holds a relatively large portion of the basin's remaining open waters by which it creates spaces for frequent trading and interactions amongst migrants of diverse ethnic groups (LCBC2014), only appeared as a seeming advantage that did not translate into any better livelihoods for local people.
2. Opportunities for seasonal mobility though largely exploited by pastoralists, have rather often pitched them against other resource users with intensified aggression over limited supplies of water and grasslands, apart from decrease in livestock production or even retention. And as it has been indicated, the continuous climate change affected herdsmen who lost thousands of herds through death or criminal cattle rustling that again pushed many out of culture to becoming rural vagabonds.
3. In spite of fishermen exploiting various water bodies seasonally, this has not led to increased catches, which a researcher has suggested decreased from 220,000 tons of fish in the 1960s to about 100,000 tons in 2000 (Ovie and Emma, 2012).
4. Different livelihood groups were inflexibly tied to water-dependent activities in a region with limited village or rural infrastructure in a manner therefore that with the traditional occupation exclusively based on pastoralism, fishing or farming, there was limited livelihood opportunities outside these three primary occupational activities with negative impact on income diversification and asset accumulation. Any alternative means of livelihood was an opportunity to be grabbed. And Boko Haram came handy as a relatively 'lucrative' business.

5. The socio-economic condition not only weakened sharing and co-operation, it has also weakened the socio-political institutions so that with increased influx of the mixed ethnic migrants pursuing the receding water in the lake, the Lake Chad Basin provide spaces for different terrorist elements with deadly and devastating violent conflicts. And consequently,

6. The lake drying has meant a destruction of the basic materials needed for a good life, as well as an unwelcomed assault on social security and economic livelihoods. All these livelihood drawbacks therefore opens up remote spaces that fan inter-group clashes and other activities that undermine human security the Boko Haram had cashed in to wreck havoc on the four countries around the Lake Chad Basin: Nigeria, Niger, Cameroon and Chad.

What the Boko Haram did was to recruit able-bodied, but pauperized, and desperate youth with least alternative towards livelihood into the movement. These youth mostly joined Boko Haram not out of knowledge about the weird ideology of Yusufiyya, but rather, it was because of the extreme poverty and lack of opportunities of life in the area. The climate change had therefore succeeded in providing Boko Haram with ready-made youths: frustrated, disillusioned and willing to identify with a group movement that had shown concern over their economic conditions (unlike the Nigerian state that was seen to have not only created, their plight but had ignored them). The Boko Haram misrepresentation of Islam, succeeded to some extent in an environment that suffered decades of poor governance by scavenging and vulture-like elites who depleted the nation's patrimony through horrendous corruption and which the Boko Haram had attributed such attitude to the western liberal democracy model the Nigerian elites have imbibed. For this, they questioned the legitimacy of the elite to govern in such extremely frustrating circumstances.

Boko Haram terror attacks on communities were such that the few local infrastructures were smashed, markets were destroyed, and farming was made difficult due to insecurity. These combined to prevent people from earning sufficient income from the sale of primary livelihood activity (agricultural produce, fishing and livestock) and to becoming attracted to the free booty, looting resources, breaking of banks and abduction for ransom. Thus, the terror group more than the state, offered a better enticement for survival to frustrated citizens. While the situation made cattle rustling to thrive among the able-bodied young men and young adults of the herding communities, the entire resource-dependent households were to be provided with alternative

income and livelihood by participating in Boko Haram activities: Achaba proceeds, looting, rustling and later abduction for ransom.

The acts of terror had taken a serious dimension that threatened not only the Nigerian state, but also neighboring countries, leading to deliberate counterinsurgency operations by the Nigerian government and neighbouring countries leading to the formation of a sub-regional military operation unit known as the Multinational Joint Task Force against Boko Haram. That apart, other volunteer vigilante groups emerged to play important roles in the counterinsurgency, though not the subject matter here, but needs be mentioned. These include the Civilian Joint Task Force (C-JTF) and local hunters among others (Ashafa 2017, Chukwuma 2017).

Boko Haram and the Security Challenges

Boko Haram falls under what could be termed indiscriminate rather than tactical terrorism. While the latter is an organized and purposeful act of terror, which formed the core activities of national liberation movements for political self-determination and is sensitive to world opinion on their activities, the former is by a group without any specific national objective, but mostly to seize power by overthrowing a government for a political change. Their activities are largely bizarre, inhuman and insensitive to world opinion. They engaged in indiscriminate shootings or bombing and attacking security national security forces, while also engaged in abductions or hostage taking. Such terrorists cause havoc in the society, create tension and instill fear in the minds of people and make them feel the state could not secure them. When Boko Haram started to create havoc, they attacked the UN office and later the Police National Headquarters all in Abuja 27th August 2011. Apart from police formations that suffered repeated and sporadic attacks, military formations were not spared. For example, the Armed Forces Command and Staff College, Jaji and as well as the Headquarters of 1 Division, Kawo, Kaduna, have both suffered similar fate. To provoke religious conflicts, Boko Haram was involved in indiscriminate attacks of religious leaders and bombing of Christian churches and later mosques, knowing how sensitive religious conflicts are and how Christians and Muslims in the country live uneasy relations.

Most of the of targets apart from places of worship included market places and motor parks and other places attracting concentrated human activities. Not only had Boko Haram taken over some Nigerian territories it declared its 'caliphate' as a state within the Nigerian state, it threatened

other parts of the country with a sense of apprehension, despair and insecurity, much as neighbouring countries too were not spared from these feelings. The destruction in the urban areas and the general threat it caused forced the federal government of Nigeria to deploy troops as the police was incapable of handling the complex situation. It has been the tradition in Nigeria to deploy troops in such kind of situation and by December 2010, the military Joint Task Force (JTF) was formed to deal with the security situation to mainly to cover the North East (Usman, 2017). To strengthen the JTF activities after a review of the situation, the Nigerian Army renamed the operation to Operation Restore Order I, created in July 2011 to confront the activities of the insurgents who had established a firm base in and around Maiduguri. Thereafter, Operation Restore Order II was established on September 2011 and which was further renamed Operation Restore Order III in November 2011 to focus on Bauchi and Yobe States, respectively to cover the entire northeastern part of the country the theatre of the Boko Haram terrorism (see Abdulhamid, 2017 and Usman 2017).

The ferocious attacks by Boko Haram not only led to the declaration of a State of Emergency on Borno, Adamawa and Yobe States in May 2013 with an operation code named “Operation BOYONA” to cover the areas under the State of Emergency, but that the taking over of some Local Government areas of Borno State as well as some rural areas in Adamawa State, the Nigerian Army Headquarters created the 7 Division to flush out the terrorists out of their stronghold in Maiduguri from where they retreated into remote communities and camps such as Sambisa, and Bagadaza among others. This did not stop the terrorists in December 2013 from attacking the Nigerian Air Force Base in Maidufuri as well as an Army barracks and a Police Division all in Maiduguri. The attacks led to the destruction of two helicopters and three decommissioned aircrafts (Usman 2017). In fact, between 2011 and 2014, Boko Haram devastating attacks made the public to lose confidence in the ability of the military to defend the nation and people begin to see no relevance on the State of Emergency earlier declared and the capacity of the Nigeria Army to even deal with the situation. The indiscriminate attacks were such that almost 3 million people were rendered as Internally Displaced Persons living in IDP camps and surviving at the mercy of international humanitarian assistance. The humanitarian crisis this created was examined in detail elsewhere and the story is devastatingly revealing (Nuhu 2017 and Bagu 2017). The story of abduction, especially of the Chibok school girls and of recent the Dapchi school girls, the massive destruction of urban infrastructure and rural livelihood and the capacity to incite inter-religious war were among the devastating security

challenges of the Boko Haram terrorist activities in Nigeria. To counter these acts of terrorism, the various JTFs, the coded military operations did not adequately solved the problem, which led to the formation of informal armed group such as the Civilian Joint Task Force, local hunters and other vigilante groups (Ashafa and Mohammed, 2017).

Conclusion

There are multifarious factors associated with the Boko Haram phenomenon in Nigeria, but which the paper selects the climate change for interrogation. It emerged at a time of democratic rule after a long period of military dictatorship and when the lease of democratic freedom prompted the launching of the Islamic sharia in most Muslim predominated States in the Nigerian federation. The nucleus of the movement was disappointed in the flagrant corruption and profligacy of the newly established democratic leaders at a time both the economy and climate were both harsh and hard. To many youth involved in Boko Haram that became its fighting force, it wasn't out of any religious conviction or deliberately informed Islamic ideological paradigm. Rather, the economic condition in the Lake Chad Basin was so catastrophic that left majority of people with little or no alternative means of survival. It rendered many youth not only out of occupation but also out of culture when depending on farming, herding and fishing, the three main rural occupations around the Lake Chad difficult. Survival was the main issue. On the other hand, the neglect by government and investors in the Lake Chad area rendered the area lacking in both basic infrastructure, as well as in welfare and modern facilities. Even Maiduguri the largest and economic nerve centre of the north eastern region of Nigeria that even served as a market to the Central African Republic, comparative lagged behind in development. Yet the desolate rural poverty made Maiduguri attractive to rural youth who were rendered out of culture and were desperate to survive pitiful environmental and economic conditions. The climate change had aggravated youth frustration and desperation in both difficult economy and environment. It consequently released abundant 'army' of unemployed and unskilled but desperate youths for Boko Haram to cajole and recruit into the movement and as its soldiers. While the leadership of Boko Haram was well informed in ideological weirdness and manipulation of Islam, it hinged on the Salafist ideology that was driving global terror. To this end, many of these youths who served as Boko Haram soldiers and engaged in the acts of terrorism were a bunch of hungry young people the climate change had affected rather badly.

Abdullahi Musa Ashafa PhD, was a graduate of History at the Bayero University, Kano and University of Jos-Nigeria respectively. He is a Professor of Military and Diplomatic History at the Kaduna State University, He was formerly at the Academic Branch of the Nigerian Defence Academy as a Lecturer and later as a Senior Research Fellow at the Nigerian Institute of International Affairs, Lagos-Nigeria. He published extensively in Nigerian military in African and global peacekeeping, Nigerian defence system, international relations as well as on intergroup relations in Nigeria.

References

- Abdulhamid, Y.H. (Col) (2017), "Before Operation Lafiya Dole: Nigerian Army in the Counter- Insurgency Operations in the Nigerian North-East" in A.M. Ashafa and H. Jibrin (eds) *The Nigerian Army in a Democracy Since 1999: A Professional Demonstration of Professional Military Subordination to Civil Authority-Essays in Honour of Lieutenant General Tukur Yusuf Buratai*, Kaduna, Plyla Mak Publishers, 2017.
- Albert, I.O. (1999) "Ethnic and Religious Conflicts in Kano" O. Ottie and I.O. Albert (eds) *Community Conflicts in Nigeria: Management, Resolution and Transformation*, Ibadan, Spectrum Books Ltd Pp. 274-309.
- Ashafa, A.M. (2017) "The Role of Relevant Stakeholders in the Fight against Boko Haram" in Maj Gen M. Mohammed and Maj Gen L.F. Abdullahi (eds) *Global Terrorism: The Nigerian Experience in Taming Boko Haram: A Publication in Honour of Lieutenant General Yusufu Buratai*, Abuja, Nigerian Army Headquarters, 2017, Pp. 239-270.
- Bagu, C. (2017) "Humanitarian Crises in the North-East in the Pre and Post-Lafiya Dole Era: A Civil Society Perspective" in A.M. Ashafa and H. Jibrin (eds) *The Nigerian Army in a Democracy Since 1999: A Professional Demonstration of Professional Military Subordination to Civil Authority-Essays in Honour of Lieutenant General Tukur Yusuf Buratai*, Kaduna, Plyla Mak Publishers, 2017.
- Brenner, L. (1992), "The Jihad Debate between Borno and Sokoto: An Historical Analysis of Islamic Political Discourse in Nigeria", J.F. Ade Ajayi and J.D.Y. Peel, eds., *Peoples and Empires in History* London: Longman, 1992.
- Campbell, J. (2017) "Salafism in Northern Nigeria Beyond Boko Haram" <https://www.cfr.org/blog/salafism-northern-nigeria-beyond-boko-haram> Retrieved 15 August, 2017.
- Chukwuma, O.A. (2017) "Nigeria: Volunteer Vigilantism and Counter-Insurgency in the North-East" *Conflict Studies Quarterly* Issue 20, July 2017, Pp. 34-55.
- Federal Republic of Nigeria (1999) *Constitution of the Federal Republic of Nigeria*, Lagos, Government Printer.
- Global Terrorist Index 2015, "Measuring and Understanding the Impact of Terrorism" Institute for Economics and Peace, 2015 <http://economicsandpeace.org/wp-content/uploads/2015/11/Global-Terrorism-Index-2015.pdf>
- Ibrahim, J. (1998) "The State and Religion in Nigeria: Forces and Dynamics" in *Afrika Zamani*, Vol. 5 and 6, Pp. 39-66.
- Ibrahim, O.F. (1992) "Religion and Politics: A View from the North" in L. Diamond, A.H.M. Kirik-Greene and O. Oyediran (eds) *Transition without End: Nigerian Politics and Civil Society Under Babangida*, Ibadan, Vintage Publishers Pp. 509-534.
- Isichei, E. (1987) "The Maitatsine Risings in Nigeria, 1980-1985: A Revolt of the Disgruntled" in *Journal of Religion in Africa*, xvii, 3 Pp. 194-208.
- Ladan, M. T. (199) "The Role of of the Youth in Inter-Ethnic and Religious Conflicts: The Kaduna/Kano Case Study" in E. E. Uwazie, I.O. Albert and G.N. Uzoigwe (eds) *Inter-Ethnic and Religious Conflicts and Resolution in Nigeria*, Maryland, USA, Lexington Pp. 97-III.

- Lake Chad Basin Commission (LCBC) (2014). The Lake Chad Basin, <http://www.cbtl.org/en/lake-chad-basin>. Retrieved January 24, 2018,
- Lubeck, P.M. (1987) "Islamic Protest under Semi-Industrial Capitalism: 'Yan Tatsine Explained'" in D.Y.J. Peel and C.C. Stewart (eds) *Popular Islam South of the Sahara*, Manchester, Manchester University Press, Pp. 369-390.
- Kyari, M. (2017) "Historical Perspective of the Boko Haram Insurgency" in A.M. Ashafa and H. Jibrin (eds) *The Nigerian Army in a Democracy Since 1999: A Professional Demonstration of Professional Military Subordination to Civil Authority-Essays in Honour of Lieutenant General Tukur Yusuf Buratai*, Kaduna, Plyla Mak Publishers, 2017.
- Murtada, D.A. (2013) "Boko Haram in Nigeria: Its Beginning, Principles and Activities" *Daily Trust (Abuja)* 13 September, 23-24.
- Nuhu, A. (2017) "The Management of Humanitarian Crisis Arising from the Boko Haram Insurgency: The Role of National Emergency Management Agency (NEMA)" in A.M. Ashafa and H. Jibrin (eds) *The Nigerian Army in a Democracy Since 1999: A Professional Demonstration of Professional Military Subordination to Civil Authority-Essays in Honour of Lieutenant General Tukur Yusuf Buratai*, Kaduna, Plyla Mak Publishers, 2017.
- Nwanko, C. and Falola, F. (2009) "Boko Haram: Another 140 Kids Rescued, 750 Killed in Maiduguri Alone: Red Cross Victims Given Mass Burial, *The Punch (Lagos)* 3 August P.2.
- Oyegbile, O. and Lawal, A. (2009) "Shielding Patrons of Boko Haram" in *Tell Magazine (Lagos)* 17 August Pp. 67-71.
- Ovie, S., and B. Emma. (2012), "Identification and Reduction of Climate Change Vulnerability in the Fisheries of the Lake Chad Basin". *FAO Fisheries and Aquaculture Proceedings* 25: 23-71
- Uche T. Okpara, Lindsay C. Stringer, Andrew J. Dougill (2016) "Lake Drying and Livelihood Dynamics in Lake Chad: Unraveling the Mechanisms, Contexts and Responses", *Ambio* 2016, 45: Pp. 781-795.
- Usman, Y.B. (1987) *The Manipulation of Religion in Nigeria, 1977-1987*, Kaduna, Vanguard Printers and Publishers Ltd.
- Usman, S.K. (2017) "In the War on Truth, Honest Reporting Matters: The Nigeria Army Public Relations and the Media Campaign on Militancy, Terrorism and Insurgency" in A.M. Ashafa and H. Jibrin (eds) *The Nigerian Army in a Democracy Since 1999: A Professional Demonstration of Professional Military Subordination to Civil Authority-Essays in Honour of Lieutenant General Tukur Yusuf Buratai*, Kaduna, Plyla Mak Publishers, 2017.
- Saeed, A.G. (1992) "A Biographical Study of Shayk Sa'id B. Hayat and the British Policy Towards the Mahdiyya in Northern Nigeria, 1900-1960" Unpublished PhD Thesis, Bayero University, Kano.
- White, K.D. (2013). *Nature-Society Linkages in the Aral Sea Region*. *Journal of Eurasian Studies*, 4: Pp.18-33.
- Williams, P.A.T. (1997) "Religion, Violence and Displacement in Nigeria", *Journal of Asian and African Studies*, xxxii, Vol. ½, Pp. 33-49.
- Yusuf, M. (2009), *This is our Doctrine and Method of Proselytization*, Maiduguri, 2009.

MOTIVATING FACTORS INFLUENCING KNOWLEDGE SHARING BEHAVIOUR AMONG ACADEMIC STAFF

AMER HATEMLEH

PhD, Irbid National University, Jordan

ABSTRACT

Effective knowledge sharing among academic staff has become a rising concern among researchers. To date, motivation has been recommended as a vital way to increase knowledge sharing behaviour among academic staff. However, limited empirical research has been conducted to uncover the motivational factors among academic staff. Therefore, the aim of this paper is to determine the intrinsic and extrinsic motivation factors that influence academic staff behaviour in terms of knowledge sharing. The result revealed that motivation has a direct influence on academic staff intention of knowledge sharing behaviour. Furthermore, intrinsic factors were found to have greater positive influence than extrinsic factors on academic staff intention of knowledge sharing behaviour. Achievement and quality of supervision were found to be dominating motivation factors. Therefore, universities should provide and implement the policies that recognize academic staff achievement and select the qualified leader to lead and direct the academic staff towards successful knowledge sharing.

Keywords: Boko Haram, Climate Change, Lake Chad Basin, Terrorism, Insurgency, Counterinsurgency

Introduction

The education sector is the backbone of any country to be counted as a developed and innovative country. With education, many changes occur in technology, labour market patterns, people's life style and global environment. Universities are one of the main components of the education sector, and it is a well-known fact that universities are the ideal place for knowledge creation (Cronin, 2001), and play an essential role in the field of knowledge development, to provide ideas, insights and disseminate new products and services that improve and develop the society (Rowley, 2000; Martin & Marion, 2005; Jing et al., 2012 Goh & Sandhu, 2013). To leverage more from academic staff knowledge, universities implement different systems and strategies to increase the productivity of knowledge creation and dissemination, such as knowledge management system (Rowley, 2000; Zoubi, 2009; Muhammad et al., 2011; Fidalgo Blanco et al., 2014) and collaborative knowledge sharing strategy (Kumaraswamy & Chitale, 2012). Furthermore, Amin et al. (2011b) suggest an activity called special interest group research to improve the research activity among academic staff by grouping the academic staff based on their research interest and concern.

Universities as specialists and experts in managing and sharing knowledge are considered as knowledge-based organizations (Ye et al., 2005). Previous studies found that universities have an embedded culture and environment of knowledge sharing (Jain et al., 2007; Bin et al., 2008; Fullwood et al., 2013). Moreover, successful knowledge sharing among academic staff was found to have a positive effect on university performance (Muhammad et al., 2011; Kumaraswamy & Chitale, 2012 Khalil and Shea, 2012). Academic staffs as knowledge workers are the most important resource for university and their main duties related to knowledge sharing and dissemination (Rowley, 2000; Jain et al., 2007). In addition, there is a widespread recognition among the academic staff regarding the importance of knowledge sharing (Machado et al., 2011; Fullwood et al., 2013) and how it affects their role in university which includes teaching, supervision, research and publication (Masron et al., 2012).

Results from previous studies demonstrate a strong and consistent association between knowledge sharing and motivation in various organizational types (Rowley, 1996; Sharratt & Usoro, 2003; Ye et al., 2005; Tohidinia & Mosakhani, 2010; Wang & Noe, 2010; Javadi et al., 2012; Welschen et al., 2012; Hau et al., 2013; Sajeva, 2014; Shanshan, 2014; Yeon et al., 2015). Furthermore, there is a good volume of published studies describing the role and influence of

intrinsic and extrinsic motivation towards successful knowledge sharing among employees (Ipe, 2003; Lin, 2007; Cho et al., 2007; Amin et al., 2011a; Hung et al., 2011; Bakan et al., 2011; Da Silva & França, 2012; Olatokun & Nwafor, 2012; Welschen et al., 2012; Shanshan, 2014; Susanty et al., 2014).

Compared to other organizations, universities tend to rely more on knowledge sharing. However, knowledge sharing best practices among academic staff has received relatively limited attention until now (Fullwood et al., 2013; Chong et al., 2014). Despite the growing body of literature that recognizes the importance of academic staff motivation in the development of the higher education institutions (Rowley, 1996; Machado et al., 2011; Mawoli & Babandako, 2011; Siddique et al., 2011; Abdulsalam & Mawoli, 2012; Rahab & Wahyuni, 2013), limited empirical research to determine the effective intrinsic and extrinsic motivation factors for knowledge sharing behaviour among academic staff has been conducted (Amin et al., 2011a). More specifically, academic staff in Jordanian universities were found to be less motivated than administrative staff regarding knowledge sharing (Alhammad et al., 2009) and their participation in knowledge management system and knowledge sharing is still at a moderate level (Al-Omari et al., 2013). Therefore, this study tries to fill the lack of insufficient empirical research in the current literature by determining the motivation factors from intrinsic as well as the extrinsic perspective that influence the knowledge sharing behaviour of academic staff in Jordanian universities.

RESEARCH MODEL AND HYPOTHESES

Theory of Reasoned Action (TRA)

The Theory of Reasoned Action (TRA) by Fishbein & Ajzen (1975) stated that individual belief and attitude can clarify most human behaviour. The theory was found very suitable to predict a wide range of human behaviours, which explain the intention and real actual behaviour of individual (Chang, 1998; Slocombe, 1999). In addition, According to Sheppard et al. (1988), TRA is effective when used to predict the real behaviour. In general, TRA believes that human beings are logical, and people make decisions based on relational motivation. According to TRA, individual behaviour can be determined by three elements namely attitude, subjective norms and behavioural intention and the effective way to predict whether an individual will perform a specific behaviour is by simply asking if he/she intends to perform that behaviour (Fishbein &

Ajzen, 1975). More precisely, the theory asserts that the most important determinants of behaviour are the behavioural intention. Behavioural intention is an indication of individual's readiness to engage in behaviour and its turn into as a function of individual's attitude toward behaviour.

In the context of Jordanian universities, academic staff attitude, expectations and practises of knowledge management were found at a moderate level; hence, it can be assumed that academic staffs have a moderate level of knowledge sharing intention (Al-Omari et al., 2013). In addition, Alhammad et al. (2009) stated that academic staffs have very low motivation and intention and a lack of interest regarding sharing knowledge. However, the existing literature on Jordanian universities lacks clarity regarding academic staff intention towards their behaviour of knowledge sharing. Therefore, empirical research will clarify whether knowledge sharing intention results in the real behaviour of knowledge sharing among academic staff in Jordanian universities. Hence, it is suggested that:

H₁) There is a relationship between knowledge sharing intention and knowledge sharing behaviour among academic staff in Jordanian universities.

According to Deci and Ryan (2000), motivation is a salient factor that influences individual behaviour and also knowledge sharing intention (Lin, 2007; Olatokun and Nwafor, 2012; Hau et al., 2013). The term motivation refers to "the reasons underlying behaviour" (Guay et al., 2010). Motivation is "the attribute that moves us to do or not to do something" (Broussard & Garrison, 2004). Deci and Ryan (2000) distinguish between the two different types of motivation (intrinsic and extrinsic) based on the reasons or goals that provide rise to action. Intrinsic motivation refers to doing something because it is interesting or enjoyable rather than relying on external pressures or a desire for reward. Meanwhile, extrinsic motivation refers to doing something because it leads to a separable outcome. Extrinsic motivation comes from outside of the individual. Numerous researchers have revealed that the quality of experience and performance can be very different when an individual is behaving for intrinsic versus extrinsic reasons (Ryan & Deci, 2000).

According to Fishbein and Ajzen (1975), intention is assumed to capture the motivation factors that influence the individual's intention to behave. In general, motivation was found to be an important factor that influences employees' intention to share knowledge (Bock et al., 2005; Vera-Munoz et al. 2006; Welschen et al., 2012; Hau et al., 2013; Shanshan, 2014). In addition,

Cheng et al. (2009) stated that knowledge sharing intention provides a decision for individual to participate in knowledge sharing behaviour and it is affected by internal and external factors. However, effective knowledge sharing among individuals cannot occur without a strong personal motivation (Stenmark, 2000). Therefore, both intrinsic and extrinsic motivation factors are important motivation factors for individual intention toward knowledge sharing behaviour. Consequently, integrating the motivation factors (intrinsic and extrinsic) with the Theory of Reasoned Action (TRA) will provide a greater explanation regarding the motivation factors that influence academic staff intention toward their behaviour of knowledge sharing.

Intrinsic Motivation and Knowledge Sharing

In general, intrinsic motivation refers to the relationship between a person and the job. Researchers have defined intrinsic motivation in terms of the task while others defined it in terms of satisfaction (Deci, 1975). Ryan and Deci (2000) defined intrinsic motivation as a way of doing the activity for the inherent satisfaction rather than some separable consequence. Therefore, intrinsic motivation refers to engaging and to the inherent satisfaction derived from an activity, or it can be derived from the experience. Previous studies revealed that the crucial role of intrinsic motivators can explain human intention for real behaviour (Baumeister & Leary, 1995) including knowledge sharing activities (Osterloh & Frey, 2000). Previous studies found there is a positive relationship between intrinsic motivation and knowledge sharing (Lin, 2007; Welschen et al., 2012; Hau et al., 2013; Olatokun & Nwafor, 2012; Sajeve, 2014; Shanshan, 2014) in various types of organizations. Among these empirical studies knowledge self-efficacy, enjoyment of helping others, recognition and achievement were found to have effective motivational influence on knowledge sharing. Therefore, this study will examine if these intrinsic motivation factors have a positive influence on academic staff intention for knowledge sharing behaviour. Therefore, it is suggested that:

H₂) Intrinsic motivation factors positively influence academic staff's intention toward knowledge sharing behaviour.

Knowledge Self-Efficacy and Knowledge Sharing

Self-efficacy has been defined as the decision of individuals to organize and take the action required to achieve certain levels of performance. In addition, individual behaviour to do any action is influenced by self- efficacy beliefs (Bandura, 1986). Through knowledge sharing

activities, employees will be more satisfied to enhance their own self-efficacy and that will increase their level of confidence. Furthermore, employee's confidence will also help them to increase sharing their own knowledge both inside and outside organization boundaries when they have the opportunity (Wasko & Faraj, 2000). Previous researchers revealed that a confident employee has more ability to provide knowledge to others and they can accomplish their tasks (Constant et al., 1994; Bock & Kim, 2001; Khalil and Shea, 2012). Thus, knowledge self-efficacy can provide positive intention toward knowledge sharing and it will be achieved when people believe that their knowledge can solve any problem in the workplace and that knowledge can increase the work efficiency (Constant et al., 1994; Hargadon, 1998). Welschen et al. (2012) found that self-efficacy motivated employees to share their knowledge of each other and they have the ability to provide knowledge that can be useful for the organizations' success. Sajeva (2014) stated that when employees participate in knowledge sharing process they will learn from others and gain new knowledge and ideas, which will help them to understand more resulting in feeling greater self-efficacy and self-confidence. Consequently, knowledge self-efficacy can be considered as an intrinsic motivation factor that influences the intention of the academic staff toward knowledge sharing behaviour. Hence, it is suggested that:

H2a) knowledge self-efficacy positively influences knowledge sharing intention towards knowledge sharing behaviour among academic staff.

Enjoyment and Knowledge Sharing

Another concept for intrinsic motivation is the enjoyment of helping others. Enjoyment helping others derives from the notion of altruism. Altruism exists when people enjoy helping others without any expectation in return. Organ (1988) defined altruism in work as employee behaviour toward helping others to solve organization problems or to accomplish tasks. In addition, Wasko and Faraj (2000) found that most employees are motivated to share knowledge when they consider their knowledge can solve the problem and doing so provides them with a feeling of enjoyment. Through knowledge sharing, individuals feel a sense of usefulness when they giving give advice to others and that makes them feel enjoyment, a sense of meaning due to their helping others and the usefulness of their expertise and knowledge (Sajeva, 2014). Consequently, enjoyment in helping others can be considered as an intrinsic motivation factor that influences the intention of the academic staff toward knowledge sharing behaviour. Hence, it is suggested that:

H2b) enjoyment in helping others positively influences knowledge sharing intention towards knowledge sharing behaviour among academic staff.

Recognition and Knowledge Sharing

When knowledge has commercial and scientific value it is viewed as highly valued knowledge, thus, it could be difficult to share. Therefore, when individuals believe that the knowledge they possess is highly valuable, their process of knowledge sharing can be effected by a few decisions such as what knowledge to share (tacit or explicit), who to share the knowledge with and when is the right time to share it (Andrews & Delahaye, 2000). In addition, when individuals share valuable knowledge they tend to claim the emotional ownership of this knowledge (Jones & Jordan, 1998). This sense of ownership knowledge comes from the fact that individual knowledge can be linked to their status, reputation and career development (Andrews & Delahaye, 2000). Moreover, the individual looks forward to being recognized by the organization and also from individuals (Brown & Woodland, 1999; Jarvenpaa & Staples, 2001; Wah et al., 2007). Therefore, recognition is an important incentive for knowledge sharing, because employees want their organizations to be appreciative of their good work (Sutton, 2006). In organizations such as universities in which the individual's knowledge becomes the primary source of value, sharing this knowledge might potentially result in the feeling of losing their valuable knowledge which can create an unwillingness to engage in knowledge sharing activities. Therefore, universities should recognize the academic who shares his valuable knowledge with other staff. Consequently, recognition can be considered as intrinsic motivation factor that influences the intention of the academic staff toward knowledge sharing behaviour. Therefore, it is expected that:

H2c) recognition positively influences knowledge sharing intention towards knowledge sharing behaviour among academic staff.

Achievement and Knowledge Sharing

When individuals share their ideas and expertise in problem solving, they feel that their contribution to achievement and success of the organization should be rewarded (Sajeva, 2014). Other workers might feel achievement motivation or realize doing valuable things derived from their job or challenging task or high responsibility (Sudirman 2014). Therefore, workers feel that their achievements can provide a good opportunity for the improvement and development in

their career path, and the top management should satisfy this need of employees in order to keep workers sharing their knowledge. In universities, when academic staff share knowledge that leads to university success, they expect that the university will reward them for sharing this knowledge. Consequently, achievement can be considered as an intrinsic motivation factor that influences the intention of the academic staff toward knowledge sharing behaviour. It is suggested that:

H2d) achievement positively influences knowledge sharing intention towards knowledge sharing behaviour among academic staff.

Extrinsic Motivation and Knowledge Sharing

In general, extrinsic motivation can be defined as when a person is engaged in a task for a reward, to achieve a meaningful goal, or to increase his self-worth (Galia, 2007). Extrinsic motivation focuses more on the goal driven reason or on the benefit that can be earned and it comes from outside the individual (Ryan & Deci, 2000). Previous studies found there is a relationship between extrinsic motivation and knowledge sharing (Lin, 2007; Sohail & Daud, 2009; Bakan et al., 2011; Siddique et al., 2011; Olatokun & Nwafor, 2012; Hau et al., 2013; Shanshan, 2014) in various types of organizations. Among these empirical studies, expected organizational rewards, reciprocal benefit, organizational policy and administration and quality of supervision were found to have effective motivation influence on knowledge sharing. Therefore, this study will examine if these extrinsic motivation factors have a positive influence on academic staff intention for knowledge sharing behaviour. Hence, it is suggested that:

H3) Extrinsic motivation factors positively influence academic staff's intention toward knowledge sharing behaviour.

Expected Organizational Rewards and Knowledge Sharing

Employee's extrinsic motivation to share their knowledge is concerned with their perception of knowledge exchange (Kankanhalli et al., 2005). Thus, employees will engage in knowledge exchange based on the relationship between cost and benefit, which means comparing the effort (costs) with the rewards (benefits). If the effort is equal to or less than rewards they will continue with the exchange process, otherwise they will try to stop or ignore it (Kelley & Thibaut, 1978). Through knowledge sharing, if the costs such as time will be taken and the potential organizational reward is equal or less, they will participate. From extrinsic motivation view, individual behaviour is driven by the benefits of the action. Therefore, the main goals of extrinsic

motivation behaviour are the reward or benefit that can be gained from the organization (Kowal & Fortier, 1999). Therefore, the organizational reward can be a useful tool for motivating employees to achieve the best performance. In universities context, academic staff share knowledge in their daily work, however, when this knowledge provides innovation and higher reputation for the university, they expect to be rewarded. Thus, expected organizational rewards can be considered as extrinsic motivation factor that influences the intention of the academic staff toward knowledge sharing behaviour. Therefore, it is suggested that:

H3a) expected organizational rewards positively influence knowledge sharing intention towards knowledge sharing behaviour among academic staff

Reciprocal Benefits and Knowledge Sharing

Another concept for extrinsic motivation is reciprocity. Reciprocity acts as a benefit because it results in feelings of personal obligation and trust. Lin (2007) said that the reciprocity behaviour is based on the exchange relationship which involves economic resources (money, goods, and services) and socio-emotional resources (status, devotion, and trust). Meanwhile, Bock et al. (2005) stated that reciprocal benefits can provide an effective motivation for knowledge sharing. For example, individuals engage in knowledge sharing with the expectation that their requests will be met by others in future. In addition, if individuals believe they will receive more reciprocity benefits, they will be likely to have a high intention to share knowledge. Thus, employees believe that they can gain reciprocal benefit when they share common areas of interest, specifically sharing problems with each other. Furthermore, Kankanhalli et al. (2005) indicated that reciprocity is the salient motivator for individual's knowledge sharing. Consequently, the reciprocal benefits are considered as extrinsic motivation factor that influences the intention of the academic staff toward knowledge sharing behaviour. Hence, it is suggested that:

H3b) reciprocal benefits positively influence knowledge sharing intention towards knowledge sharing behaviour among academic staff

University Policies & Administration and Knowledge Sharing

University policies and administration were found to be a key important factor that motivates the academic staff for successful knowledge sharing (Jain et al., 2007; Amin et al., 2011b; Siddique et al., 2011). Universities need to implement the right policies and activities that strengthen the emotional bond among the academic staff such as teamwork spirit, teaching and researching skills training. Through such activities, the academic staff skills will be improved and also their level of confidence, which will lead to facilitate effective knowledge sharing (Goh & Sandhu, 2013). Furthermore, management should encourage academic staff to form groups based on their knowledge and research interests to increase the knowledge sharing activity (Amin et al., 2011b). Therefore, Jain et al. (2007) proposed some policies that universities should implement to enhance the knowledge sharing activity among the academic staff such as implementing policies that recognize and reward individuals as well as teams who share more knowledge with others, and implement the rotation policies among staff for the academic position.

Consequently, university policies and administration can be considered as the third factor of extrinsic motivation that can influence the intention of the academic staff toward knowledge sharing behaviour. Hence, it is suggested that:

H_{3c}) University policies and administration positively influence knowledge sharing intention towards knowledge sharing behaviour among academic staff.

Quality of Supervision and Knowledge Sharing

Academic leaders have more challenges than leaders in business organizations as academic leaders deal with students, faculty members and top management at the same time. In addition, the academic leader should group faculty members together and direct them in order to perform the work and empower them to do the required task. In addition, Siddique et al. (2011) stated that academic leader has great role in motivating and satisfying the faculty members by providing different kinds of rewards and as academic institutions are much different from other organizations, different motivational policies should be used by the academic leader in order to motivate the academic staff. Consequently, leaders in higher education have different challenges compared to other organizations. One of the main duties of the academic leader is supervision. The supervisor has many duties such as managing academic staff and team performance, providing orientation, adequate training, evaluating, training and motivating the academic staff. Therefore, the quality of supervision plays an effective role to enhance the knowledge sharing

behaviour of the academic staff. Consequently, quality of supervision is considered an extrinsic motivation factor that influences the intention of the academic staff toward knowledge sharing behaviour. Therefore, it is expected that:

H3d) quality of supervision positively influences knowledge sharing intention towards knowledge sharing behaviour among academic staff.

METHODOLOGY

Only private universities in Jordan were selected as the target population. Probability sampling using stratified random method was applied; the academic staff ranking was used as the sampling strata (Lecturer, Assistant professor, Associate professor and Professor). The questionnaire was the main instrument for data collection in this study. The questionnaire was given to three academic staff expert in the field of knowledge sharing from different Jordanian universities to validate the content of research instrument. On the whole, the experts believed that the research instrument is valid and acceptable for the study purpose. In addition, a pilot study was conducted to detect possible problems in research instrument or design and the relevance of the instrument. A random sample of 30 academic staff in private Jordanian universities was used for the pilot study. The Cronbach's alpha values ranged from 0.802 to 0.900, as indicated in Table 2, which are above the acceptable value of 0.70 (Nunnally, 1978), which indicated good instrument reliability. The researcher handled the printed questionnaire with cover letters that contain an introduction about the research, purpose and aim of the study along with an instruction paper that describes to whom the academic staff should return the filled questionnaire. The researcher selected a contact person in each private university to collect the filled questionnaire in order to ease the collection. Follow up calls were made by the researchers to the contact person in each private university. The response rate was 83.5% which indicates very good interaction from the

academic staff. On the basis of university name the respondents of Al-Zaytoonah University were the highest sample representing 11.2 % of the sample size (N = 35) followed by Zarqa private University at 11.0% (N = 34), and the lowest sample was from Ajloun national private university at 3.2% (N = 10). Most of the academic staff were ranked as Assistant Professor 50.8% (N = 157), and professor with the lowest present 11.0 % with sample size (N = 34). When respondents were

asked about their years of experience, 25.9 % (N =80) indicated 5 - 9 years experiences and the lowest with 13.7 % (N = 42) had 20 years of experiences or more. Majority of the respondents were male 77.6% (N = 240), while 22.3% (N = 69) were female. Based on the age of the academic staff the highest age was 45 – 54 years with 35.3 % (N = 109) and the lowest age was 25 years or less representing 0.6 % (N = 2). Table 1 shows the demographic profile for the academic staff.

Table 1: Sampling profile

Demographical (N=309)		Frequency	Percent
University Name	Al-Ahliyya Amman University	28	9.1
	Applied Science Private University	29	9.4
	Philadelphia University	25	8.1
	Isra University	28	9.1
	Petra University	25	8.1
	Al-Zaytoonah University	35	11.2
	Jerash Private University	17	5.5
	Irbid National University	11	3.6
	Zarqa Private University	34	11.0
	Princess Sumaya For Technology	13	4.2
	Amman Arab University	11	3.6
	Middle East University	17	5.5
	Jadara University	14	4.5
	American University Of Madaba	12	3.9
	Ajloun National Private University	10	3.2
Academic Rank	Lecturer	62	20.0
	Assistant Professor	157	50.8
	Associate Professor	56	18.2
	Professor	34	11.0
Experience Years	Below 5 Years	46	14.9
	5 - 9 Years	80	25.9
	10-14 Years	70	22.6
	15 - 19 Years	71	22.9
	20 Years Or More	42	13.7
Gender	Male	240	77.6
	Female	69	22.3
Age	Less Than 25	2	0.6
	25 - 34	56	18.2
	35 - 44	76	24.6
	45 - 54	109	35.3
	55 Years And More	66	21.3

Measures

Items used to operationalize the construct of intrinsic and extrinsic motivation factors, knowledge sharing intention and knowledge sharing behaviour are based on prior empirical studies and mainly adapted from previous studies that have been previously tested for reliability and validity. All constructs were measured by using the means of the multiple items based on a five-point Likert-type scale (ranging from 1 = strongly disagree to 5 = strongly agree). Table 2 lists all the items used to measure each construct. In this study, knowledge self-efficacy was measured by four items to assess the academic staff expertise and confidence in their own knowledge, and they were adapted from Lin (2007) study. In addition, enjoyment in helping others was measured by four items to assess the academic staff feeling when they shared knowledge that helps other colleagues, and they were adapted from Lin (2007) study. Meanwhile, recognition was measured by four items to assess the recognition that the university provides to the academic staff when to share this knowledge and they were adapted from Smerek and Peterson (2007) study. Also, achievement was measured by four items to assess how university recognizes the academic staff achievement that occurred through knowledge sharing activity, and they were adapted from Tan and Waheed (2011) study. Furthermore, expected organizational rewards were measured by four items to assess the academic staff agreement about salary, bonus, promotion and job security, and they were adapted from Lin (2007) study. Meanwhile, reciprocal benefits were measured by four items to assess the academic staff agreement on how knowledge sharing can increase their relationship with each other either inside the same university or outside, and they were adapted from Lin (2007) study. In addition, University policy and administration were measured by four items to assess the degree of the effective communication that occurred between the academic staff and the management and how the benefits package that academic staff receive satisfied their decision to stay at the same university, and they were adapted from Al-Mekhlafie (1994) study. Moreover, the quality of supervision was measured by five items to assess how the academic supervision of the university deals with the academic staff in terms of communication, respect and new ideas, and they were adapted from Smerek and Peterson (2007) study. Knowledge sharing intention was measured by five items to assess the academic staff intention for sharing their own experience and any official documents between each other, and they were adapted from Lin (2007) study. Finally, knowledge sharing behaviour was measured by five items to assess the degree of the academic staff participation and their real behaviour for sharing their experience, official documents that contain any new knowledge which can help and increase their own knowledge and they were adapted from Chennamaneni (2006) study.

Table 2 Results for the Research Instrument

<i>Research Construct /Measured Items</i>	<i>Items loading</i>	<i>AVE</i>	<i>CR</i>	<i>α</i>
Knowledge Self- Efficacy (KS)		0.652	0.882	.878
I am confident in my ability to provide knowledge that others in my university consider valuable	0.75			
I have the expertise required to provide valuable knowledge for my university.	0.88			
It does not really make any difference whether I share my knowledge with colleagues.	0.81			
Most other academic staff can provide more valuable knowledge than I can	0.79			
Enjoyment In Helping Others (EH)		0.569	0.841	.840
I enjoy sharing my knowledge with my colleagues	0.78			
I enjoy helping my colleagues through sharing my knowledge	0.76			
It feels good to help my colleagues by sharing my knowledge	0.78			
Sharing my knowledge with my colleagues is pleasurable	0.70			
Recognition (RE)		0.551	0.830	.825
My university recognizes my knowledge	0.69			
My knowledge contributions are valued by the members of the university, community and outside university	0.83			
I get appropriate recognition when I have done something extraordinary with the knowledge I have	0.78			
Expressions of thanks and appreciation are common in my department/ university regarding the knowledge that I share	0.66			
Achievement (AC)		0.621	0.867	.861
I am proud to work in this university because it recognizes my knowledge achievements	0.72			
I feel satisfied with my knowledge because it gives me feeling of accomplishment	0.88			
I feel that my knowledge contributed towards my university in a positive manner	0.84			
I am able to evaluate my knowledge accomplishment objectively	0.70			
Expected Organizational Rewards (EOR)		0.514	0.808	.806
I will receive a higher salary in return for my knowledge sharing	0.64			
I will receive a higher bonus in return for my knowledge sharing	0.80			
I will receive increased promotion opportunities in return for my knowledge sharing	0.72			
I will receive increased job security in return for my knowledge sharing	0.70			
Reciprocal Benefits (RB)		0.604	0.859	.856
By sharing my knowledge with my colleagues, I strengthen ties between existing members of the university and myself	0.76			
By sharing my knowledge with my colleagues, I expand the scope of my association with other university members	0.88			
I expect to receive knowledge in return when I share my knowledge with my colleagues	0.74			
I believe that my future requests for knowledge will be answered if I share my knowledge with my colleagues	0.72			
University Policies And Administration (UPA)		0.517	0.801	.802
Senior management in my university keeps academic staff informed with the new knowledge	0.68			
My university policies meet my knowledge needs.	0.75			
The administrative procedures and policies used to	0.75			

carry out the knowledge sharing program are made available to all faculty members.				
The benefits package is a significant factor in my decision to share my knowledge at the University	0.70			
Quality Of Supervision (QS)		0.644	0.901	.900
My superior creates an environment that fosters trust in order to share knowledge	0.80			
My superior treats me with respect because of my knowledge	0.77			
My superior considers my ideas and knowledge	0.81			
My superior trust my knowledge	0.83			
My superior deals effectively with poor knowledge performance	0.80			
Knowledge Sharing Intention (KSI)		0.599	0.882	0.881
I intend to share knowledge with my colleagues more frequently in the future	0.79			
I plan to share knowledge with my colleagues	0.83			
I would share internal reports and other official documents with my colleagues.	0.76			
I will always make an effort to share knowledge with my colleagues	0.74			
I intend to share knowledge with colleagues who ask me	0.74			
Knowledge Sharing Behaviour (KSB)		0.593	0.879	0.887
I shared factual knowledge from work with my colleagues	0.75			
I shared internal reports and other official documents with my colleagues	0.74			
I shared my work experiences with my colleagues	0.82			
I shared my education expertise with my colleagues	0.79			
I shared my knowledge from work with my colleagues	0.74			

Confirmatory Factor Analysis and Measurement Model

A preliminary confirmatory factor analysis (CFA) suggested that all items loaded reasonably well on their latent factors. According to Hair et al. (2012), a value of 0.50 is considered as acceptable value for factor loading in CFA test. The result revealed as indicated in Table 2 that the standard loading for the items ranged from 0.64 to 0.88. Moreover, the composite reliability (CR) was examined to have good construct reliability. According to Bagozzi and Yi (1998), a CR value of 0.6 is the acceptable value to meet the requirement of construct reliability in SEM analysis. The result revealed as indicated in Table 2 shows that the composite reliability ranged from 0.801 to 0.901. In addition, the measurement model was tested for the construct validity. The convergent validity was checked by the average variance extracted (AVE). An AVE value of 0.5 or more is used to indicate an adequate convergent validity (Hair et al., 2006). The average variance extracted values for the study constructs as indicated in Table 2 ranged from 0.514 to 0.652 which indicated adequate convergent validity. In addition, discriminant validity was assessed by comparing the squared correlation between each pair of constructs against the average of the AVEs for these two constructs. Table 3 indicates the measure has adequate discriminant validity, as the square root of the average variance extracted for each construct is greater than the levels of

correlations involving the construct. Moreover, determine to what degree any such biases exist. Harman single factor technique was used in this study to the common method variance was tested to determine to what degree any such biases exist (Harman, 1967). Specifically, an exploratory factor analysis was used to all variables to load onto a single factor and constrained so that there is no rotation (Podsakoff et al, 2003). The results revealed that all factors accounted for 33.17 percent of the total variance, which indicated that the common method bias was not a significant issue in the study (Podsakoff & Organ, 1986).

Table 3 Discriminant validity for The Research Constructs

	CR	AVE	EOR	KS	EH	RE	AC	KSB	KSI	QS	RB	UPA
EOR	0.808	0.514	0.717									
KS	0.882	0.652	0.450	0.807								
EH	0.841	0.569	0.347	0.667	0.754							
RE	0.830	0.551	0.369	0.715	0.631	0.743						
AC	0.867	0.621	0.345	0.691	0.678	0.694	0.788					
KSB	0.879	0.593	0.412	0.343	0.391	0.343	0.346	0.770				
KSI	0.882	0.599	0.570	0.691	0.669	0.654	0.665	0.606	0.774			
QS	0.901	0.644	0.638	0.411	0.394	0.392	0.382	0.332	0.566	0.803		
RB	0.859	0.604	0.643	0.404	0.384	0.341	0.298	0.399	0.552	0.686	0.777	
UPA	0.801	0.517	0.620	0.380	0.334	0.297	0.255	0.403	0.505	0.680	0.676	0.719

Moreover, the researcher tested the structural model using information obtained by means of a construct that was collected from the sample of 309 academic staff. The structural (hypotheses) model provides good model fit with the collected data. The Chi-square = 100.425, DF = 34, $\chi^2/DF = 2.954$, NFI = 0.931, GFI = 0.945, AGFI = 0.911, CFI = 0.953, RMSEA = .080. Figure 1 shows the research model with the path values for each construct.

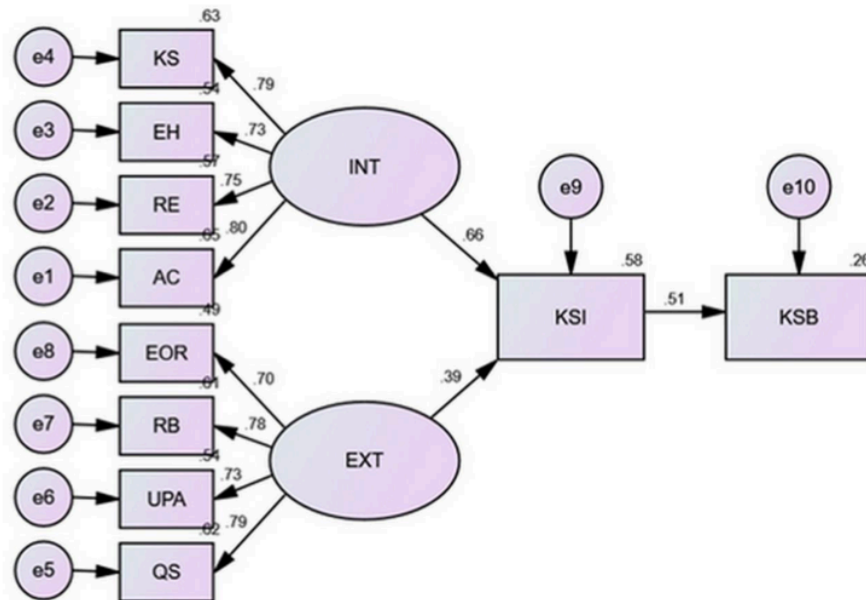
Figure 1 Research (hypotheses) Model

DISCUSSION AND IMPLICATION

This study set out with the aim of assessing the importance of motivation factors (intrinsic and extrinsic) on academic staff intention toward knowledge sharing behaviour in Jordanian universities. Consistent with expectations, the result indicated that both intrinsic and extrinsic motivation factors have a positive influence associated with the intention of academic staff for knowledge sharing behaviour in Jordanian

universities. In addition, the results of this study indicate that intrinsic motivation factors have more positive influence than extrinsic motivation factors on academic staff intention towards knowledge sharing behaviour. Therefore, universities should be more concerned with intrinsic motivation factors in order to achieve successful knowledge sharing behaviour among academic staff. First, the current study found that there is a positive relationship between knowledge sharing intention and knowledge sharing behaviour among the academic staff in Jordanian universities ($\beta = .506$, $P < 0.00$, R^2 for KSI = .58 and R^2 for KSB = .26). This result is consistent with previous findings (Bock et al., 2005; Iqbal et al., 2011; Goh & Sandhu, 2013). Therefore, determining the motivation factors (intrinsic and extrinsic) that influence the academic staff intention is important for successful knowledge sharing behaviour.

The current study found that intrinsic motivation factors have a positive influence on academic staff intention of knowledge sharing behaviour ($\beta = 658, P < 0.00$). This finding is consistent with past findings (Welschen et al., 2012; Shanshan, 2014). Among the four intrinsic factors, achievement was found as the primary motivation for academic staff intention towards knowledge sharing behaviour ($\beta = 803, P < 0.00$). This result is consistent with previous findings (Chong et al., 2014; Sajeve, 2014). This result may be explained by the fact that academic staffs feel that their contribution to achievement and success to the university must be rewarded. In addition, their achievement can provide a good opportunity for the improvement and development in their academic career path. Therefore, universities must apply practices that can obtain a high sense of achievement and a joy of growth from knowledge-sharing activities such as involving academic staff in decision-making or problem-solving process.

Consistence with prior research, knowledge self-efficacy was also found to be an important motivation factor for knowledge sharing behaviour among the academic staff ($\beta = 794, P < 0.00$). This result was consistent with other researcher findings that knowledge self-efficacy is a motivation factor for knowledge sharing behaviour (Lin, 2007; Tohidinia & Mosakhani, 2010; Olatokun & Nwafor, 2012; Welschen et al., 2012; Hau et al., 2013). A possible explanation for these results may be that academic staff have more confidence in their knowledge and they have the ability to provide knowledge to others that can help them to accomplish their tasks. Therefore, academic staff leaders must enhance the perceptions of knowledge self-efficacy among the academic staff by indicating that their knowledge can make a significant contribution to the university and to society.

Another important finding was that recognition is also an essential intrinsic motivation factor for knowledge sharing behaviour ($\beta = 755, P < 0.00$). This result is consistent with the other researcher findings (Jain et al., 2007; Da Silva & França, 2012; Sajeve, 2014; Susanty et al., 2014). These results are likely to be related to academic staff tendency to claim an emotional ownership of owning a valuable knowledge and they look to get recognition and respect from university, supervisors and peers. Thus, university top management should recognize the academic staff who shares valuable knowledge by different methods such as financial rewards or enhancing the staff members' status inside the university. In addition, the result revealed that enjoyment in helping others is an important intrinsic motivation factor for knowledge sharing ($\beta = 735, P < 0.00$). The result was consistent with other researchers finding that enjoyment in helping others is a motivation factor for knowledge sharing (Lin, 2007; Olatokun & Nwafor,

2012; Welschen et al., 2012) Hau et al., 2013; Sajeva, 2014). A possible explanation for this might be that academic staff feel that the help they provide through knowledge sharing is meaningful and useful. Hence, academic staff leaders must increase the level of enjoyment among the academic staff by enhancing their positive mood regarding the usefulness of their help and how their knowledge can solve problems of other academic staff or the university.

Furthermore, the current study further supports the idea that extrinsic motivation factors have a significant positive influence on academic staff intention for knowledge sharing behaviour ($\beta = 386, P < 0.00$). This result is consistent with previous findings (Jain et al., 2007; Hung et al., 2011; Jahani et al., 2011; Amin et al., 2011b; Shanshan, 2014). One interesting finding is the quality of supervision as extrinsic motivation factor was found to have the highest influence on the academic staff intention for knowledge sharing in private Jordanian universities ($\beta = 785, P < 0.00$). This result is consistent with the Siddique et al. (2011) findings. This

result may be explained by the fact that academic supervision plays an effective role in motivation and enhances the academic staff intention for knowledge sharing behaviour. Thus, university management should select a qualified academic leader who can motivate, lead, direct and eliminate the effect of any barrier that may influence the knowledge sharing activity among the academic staff. Another important finding was that reciprocal benefits have positive motivation influence on academic staff intention of knowledge sharing ($\beta = 780, P < 0.00$), This result was consistent with other researchers' findings (Cho et al., 2007; Gururajan and Fink, 2010; Hung et al., 2011; Olatokun & Nwafor, 2012; Hau et al., 2013; Endres & Chowdhury, 2013). A possible explanation for this might be that academic staff believes they can obtain reciprocal benefits from others when sharing their knowledge. Thus, effective knowledge sharing requires active academic staff participation efforts to targeted reciprocal relationships for generating a positive knowledge sharing environment in universities. Consequently, one important role for the academic staff leaders is to improve the perceptions of reciprocal benefits among the academic staff. Another important finding was that University policies and administration also influenced academic staff intention for knowledge sharing ($\beta = 735, P < 0.00$). This result is consistent with the consistent with studies findings (Jain et al., 2007; Amin et al., 2011a; Siddique et al., 2011). A possible explanation for this might be that academic staff believes that university policies play an effective role in motivating them for knowledge sharing. Therefore, universities need to implement the right policies and activities that can strengthen the emotional bond and communication among the academic staff which lead to facilitate knowledge sharing. One

unexpected finding was that expected organizational reward had a positive influence on academic staff ($\beta = 700, P < 0.00$). This result was inconsistent with other researcher's findings (Lin, 2007; Wah et al., 2007 Olatokun & Nwafor, 2012; Hau et al., 2013). Therefore, academic staff in private Jordanian universities emphasized organizational rewards, which mean universities rewards are an important key to successful knowledge sharing among the academic staff in private Jordanian universities and this was supported by Wah et al. (2008) findings. Thus, university management should apply the rewards systems in order to have successful knowledge sharing behaviour among the academic staff.

LIMITATIONS AND RECOMMENDATIONS FOR FUTURE RESEARCH

As with any other research, this paper is not without limitation. Therefore, this limitation should be addressed and overcome by future research. Due to time and monetary constraint, this study focuses only on academic staff in Jordanian universities, since it is limited to the private universities in Jordan. Future research should include public universities in Jordan. Hence, a comparative study between the private and public universities can be carried out. In addition, future study should focus on the longitudinal time frame. Although longitudinal study consumes a lot of time and cost, it will allow future researchers to track changes and trends regarding academic staff behaviour for knowledge sharing. Moreover, this paper adapted the survey method for the data collection. However, another method of data collection such as interview may provide more depth information about the motivation factors among academic staff. Finally, this research investigated the major intrinsic and extrinsic motivating factors that influence the academic staff behaviour for knowledge sharing. Therefore, there can be other intrinsic and extrinsic motivating factors and also a mediator and moderators such as demographic characteristics and situational variables factors that might influence the knowledge sharing behaviour. It will be investigated more broadly in future studies.

CONCLUSION

In conclusion, knowledge sharing is a dynamic tool for all organizations, especially for universities. Academic staff motivation has been identified as a key enabler for successful knowledge sharing behaviour. Hence, the understanding of intrinsic and extrinsic motivating factors that influence the knowledge sharing behaviour of academic staff is also important. The main goal of the current study was to determine the intrinsic and extrinsic motivation factors that influence the academic staff intention towards knowledge sharing behaviour. This study

attempted to fill the gap in the current theoretical literature on knowledge sharing from both intrinsic and extrinsic motivation perspective in universities sector. Despite the limitations, this study fills the gap in previous research by concentrating on the relationship between motivating and knowledge sharing intention towards knowledge sharing behaviour. In addition, this study set out to investigate the impact of intrinsic and extrinsic motivating factors on knowledge sharing behaviour among academic staff. It is hoped that

References

- Abdulsalam, D., & Mawoli, M. A. (2012). Motivation and job performance of the academic staff of state universities in Nigeria: The case of Ibrahim Badamasi Babangida University, Lapai, Niger State. *International Journal of Business and Management*, 7(14), 142-148.
- Alhammad, F., Al Faori, S., & Abu Husan, L. S. (2009). Knowledge sharing in the Jordanian universities. *Journal of Knowledge Management Practice*, 10(3), 1-9.
- Al-Mekhlafie, M. S. (1994). A study of job satisfaction of faculty members at Sana'a University in the Republic of Yemen: Systematic analyses based on Herzberg's two-factor theory, university of Pittsburgh, Pennsylvania.
- Al-Omari, A. A., Abu Tineh, M. A., Khasawneh, & A, S. (2013). Faculty members' attitudes, expectations and practises of Knowledge Management at higher education institutions in Jordan. *International Journal of Management in Education*, 7(1-2), 199-211.
- Amin, A., Hassan, M. F., Ariffin, M. B. M., & Rehman, M. (2011a). Knowledge sharing: two-dimensional motivation perspective and the role of demographic variables. *Journal of Information & Knowledge Management*, 10(02), 135-149.
- Amin, S. H. M., Zawawi, A. A., & Timan, H. (2011 b). To share or not to share knowledge: Observing the factors. Paper presented in Humanities, Science and Engineering (CHUSER), 2011 IEEE Colloquium on (pp. 860-864).
- Andrews, K. M., & Delahaye, B. L. (2000). Influences on knowledge processes in organizational learning: The psychosocial filter. *Journal of Management studies*, 37(6), 797-810.
- Bagozzi, R. P., & Yi, Y. (1988). On the evaluation of structural equation models. *Journal of the Academy of Marketing Science*, 16(1), 74-94.
- Bakan, İ., Erşahan, B., & Büyükbeşe, T. (2011). A Research Model on the Effects of Job Satisfaction, Extrinsic Motivation and Knowledge Sharing Intention on Knowledge Sharing. *China-USA Business Review*, 10(10), 1047-1060.
- Bandura, A. (1986). *Social foundations of thought and action: A social cognitive theory*. NJ, US, Prentice-Hall, Inc.
- Baumeister, R. F., & Leary, M. R. (1995). The need to belong: desire for interpersonal attachments as a fundamental human motivation. *Psychological bulletin*, 117(3), 497-529.
- Bin, L., Hong, Z., & MingLiang, W. (2008, December). An Exploration of the Relationship between Knowledge Sharing and Organizational Cultures in Education. Paper presented in Knowledge Acquisition and Modeling, 2008 (KAM'08, International Symposium) pp. 429-433.
- Bock, G. W., & Kim, Y. G. (2001). Breaking the myths of rewards: An exploratory study of attitudes about knowledge sharing. *Information Resources Management Journal*, 15(2), 14-21.
- Bock, G. W., Zmud, R. W., Kim, Y. G., & Lee, J. N. (2005). Behavioral intention formation in knowledge sharing: Examining the roles of extrinsic motivators, social-psychological forces, and organizational climate. *MIS Quarterly*, 29(1), 87-111.

- Broussard, S. C., & Garrison, M. E. (2004). The relationship between classroom motivation and academic achievement in elementary school aged children. *Family and Consumer Sciences Research Journal*, 33(2), 106-120
- Brown, R. B., & Woodland, M. J. (1999). Managing knowledge wisely: A case study in organisational behaviour. *Journal of Applied Management Studies*, 8(2), 175-198.
- Chang, M. K. (1998). Predicting unethical behavior: a comparison of the theory of reasoned action and the theory of planned behavior. *Journal of Business Ethics*, 17(16), 1825-1834.
- Cheng, M. Y., Ho, J. S. Y., & Lau, P. M. (2009). Knowledge sharing in academic institutions: a study of Multimedia University Malaysia. *Electronic Journal of Knowledge Management*, 7(3), 313-324.
- Chennamaneni, A. (2007). Determinants of knowledge sharing behaviors: Developing and testing an integrated theoretical model. Unpublished doctoral dissertation, The university of Texas, Arlington.
- Cho, N., Zheng Li, G., & Su, C. J. (2007). An empirical study on the effect of individual factors on knowledge sharing by knowledge type. *Journal of Global Business and Technology*, 3(2), 1-15.
- Constant, D., Kiesler, S., & Sproull, L. (1994). What's mine is ours, or is it? A study of attitudes about information sharing. *Information systems research*, 5(4), 400-421.
- Cronin, B. (2001). Knowledge management, organizational culture and Anglo-American higher education. *Journal of Information Science*, 27(3), 129-137.
- Da Silva, F. Q., & França, A. C. C. (2012). Towards understanding the underlying structure of motivational factors for software engineers to guide the definition of motivational programs. *Journal of Systems and Software*, 85(2), 216-226.
- De Lourdes Machado, M., Soares, V. M., Brites, R., Ferreira, J. B., & Gouveia, O. M. R. (2011). A look at academics job satisfaction and motivation in Portuguese higher education institutions. *Procedia-Social and Behavioral Sciences*, 29(2), 1715-1724.
- Endres, M. L., & Chowdhury, S. (2013). The role of expected reciprocity in knowledge sharing. *International Journal of Knowledge Management (IJKM)*, 9(2), 1-19.
- Deci, E. L. (1975). *Intrinsic motivation*. New York: Plenum Press.
- Fishbein, M. and Ajzen, I. (1975), *Beliefs, Attitude, Intention and Behavior: An Introduction to Theory and Research*, Addison-Wesley Publishing, Reading, MA.
- Fidalgo Blanco, Á., Echaluze, S., Luisa, M., & García Peñalvo, F. J. (2014). Knowledge Spirals in higher education teaching Innovation. *International Journal of Knowledge Management*, 10(4), 16-37.
- Fullwood, R., Rowley, J., & Delbridge, R. (2013). Knowledge sharing amongst academics in UK universities. *Journal of Knowledge Management*, 17(1), 123-136.
- Galía, F. (2007). Intrinsic-extrinsic motivations, knowledge sharing and innovation in French firms. Paper presented in the DIME Workshop Organisational Innovation: the dynamics of organisational capabilities and design GREDEG-DEMOS, Sophia Antipolis, 15-16 November 2007

- Goh, S. K., & Sandhu, M. S. (2013). Knowledge sharing among Malaysian academics: Influence of affective commitment and trust. *The Electronic Journal of Knowledge Management*, 11(1), 38-48.
- Guay, F., Chanal, J., Ratelle, C. F., Marsh, H. W., Larose, S., & Boivin, M. (2010). Intrinsic, identified, and controlled types of motivation for school subjects in young elementary school children. *British Journal of Educational Psychology*, 80(4), 711-735.
- Gururajan, V., & Fink, D. (2010). Attitudes towards knowledge transfer in an environment to perform. *Journal of Knowledge Management*, 14(6), 828-840.
- Hair JF, Anderson RE, Tatham RL, Black WC (2006). *Multivariate Data Analysis*. 6th edition, New Jersey, Pearson Prentice Hall, Upper Saddle River.
- Hair, J. F., Sarstedt, M., Ringle, C. M., & Mena, J. A. (2012). An assessment of the use of partial least squares structural equation modeling in marketing research. *Journal of the Academy of Marketing Science*, 40(3), 414-433.
- Hargadon, A. (1998). Firms as knowledge workers. *California management review*, 40(3), 209-227.
- Harman, H. H. (1967). *Modern Factor Analysis*. Chicago, IL. University of Chicago Press.
- Hau, Y. S., Kim, B., Lee, H., & Kim, Y. G. (2013). The effects of individual motivations and social capital on employees' tacit and explicit knowledge sharing intentions. *International Journal of Information Management*, 33(2), 356-366.
- Hung, S. Y., Durcikova, A., Lai, H. M., & Lin, W. M. (2011). The influence of intrinsic and extrinsic motivation on individuals' knowledge sharing behavior. *International Journal of Human-Computer Studies*, 69(6), 415-427.
- Ipe, M. (2003). Knowledge sharing in organizations: A conceptual framework. *Human Resource Development Review*, 2(4), 337-359.
- Iqbal, M. J., Amran, R., & Jolae, A. (2011). Academic Staff Knowledge Sharing Intentions and University Innovation Capability. *African Journal of Business Management*, 5(27), 11051-11059.
- Jahani, S., Ramayah, T., & Effendi, A. A. (2011). Is reward system and leadership important in knowledge sharing among academics? *American Journal of Economics and Business Administration*, 3(1), 87-94.
- Jain, K. K., Sandhu, M. S., & Sidhu, G. K. (2007). Knowledge sharing among academic staff: A case study of business schools in Klang Valley, Malaysia. *JASA* 2, 23-29.
- Jarvenpaa, S. L., & Staples, D. S. (2001). Exploring perceptions of organizational ownership of information and expertise. *Journal of Management Information Systems*, 18(1), 151-183.
- Javadi, M. H. M., Zadeh, N. D., Zandi, M., & Yavarian, J. (2012). Effect of Motivation and Trust on Knowledge Sharing and Effect of Knowledge Sharing on Employee's Performance. *International Journal of Human Resource Studies*, 2(1), 210-221.
- Jing, F., Chakpitak, N., Goldsmith, P., Sureephong, P., & Kunarucks, T. (2012). Creating a knowledge supply chain for e-tourism curriculum design: Integrating knowledge management and supply chain management. *International Journal of Knowledge Management (IJKM)*, 8(4), 71-94.

- Jones, P., & Jordan, J. (1998). Knowledge orientations and team effectiveness. *International Journal of Technology Management*, 16(1-3), 152-161.
- Kankanhalli, A., Tan, B. C., & Wei, K. K. (2005). Contributing knowledge to electronic knowledge repositories: an empirical investigation. *MIS Quarterly*, 29(1), 113-143.
- Kelley, H. H., & Thibaut, J. W. (1978). *Interpersonal relations: A theory of interdependence*. New York: Wiley.
- Khalil, O. E., & Shea, T. (2012). Knowledge sharing barriers and effectiveness at a higher education institution. *International Journal of Knowledge Management (IJKM)*, 8(2), 43-64.
- Kowal, J., & Fortier, M. S. (1999). Motivational determinants of flow: Contributions from self-determination theory. *The Journal of Social Psychology*, 139(3), 355-368.
- Lin, H. F. (2007). Effects of extrinsic and intrinsic motivation on employee knowledge sharing intentions. *Journal of Information Science*, 33(2), 135-149.
- Martin, J.S. and Marion, R. (2005), "Higher education leadership roles in knowledge processing", *The Learning Organization*, 12(2), 140-151.
- Masron, T. A., Ahmad, Z., & Rahim, N. B. (2012). Key performance indicators vs key intangible performance among academic staff: A case study of a public university in Malaysia. *Procedia-Social and Behavioral Sciences*, 56 (2012), 494-503.
- Mawoli, M. A., & Babandako, A. Y. (2011). An evaluation of staff motivation, dissatisfaction and job performance in an academic setting. *Australian Journal of Business and Management Research*, 1(9), 1-13.
- Muhammad, N., Rahman, B. A., Abd Rahman, W. Z., Idris, A. R., Sabri, S. M., & Jusoff, K. (2011). Knowledge management practices (KMP) and academic performance in Universiti Teknologi Mara (UITM) Terengganu, Malaysia. *World Applied Sciences Journal*, 12(12), 21-26.
- Nunnally, J. C. (1978). *Psychometric theory*. New York: McGraw-Hill.
- Olatokun, W., & Nwafor, C. I. (2012). The effect of extrinsic and intrinsic motivation on knowledge sharing intentions of civil servants in Ebonyi State, Nigeria. *Information Development*, 28(3), 216-234.
- Organ, D. W. (1988). *Organizational citizenship behavior: The good soldier syndrome*. Lexington, Mass: Lexington Books.
- Osterloh, M., & Frey, B. S. (2000). Motivation, knowledge transfer, and organizational forms. *Organization Science*, 11(5), 538-550.
- Podsakoff, P. M., & Organ, D. W. (1986). Self-reports in organizational research: Problems and prospects. *Journal of management*, 12(4), 531-544.
- Podsakoff, P. M., MacKenzie, S. B., Lee, J. Y., & Podsakoff, N. P. (2003). Common method biases in behavioral research: a critical review of the literature and recommended remedies. *Journal of Applied Psychology*, 88(5), 879-903.
- Rahab, & Wahyuni, P. (2013). Predicting Knowledge Sharing Intention Based on Theory of Reasoned Action Framework: An Empirical Study on Higher Education Institution. *American International Journal of Contemporary Research*, 3(1), 138-147.

- Rowley, J. (1996). Motivation and academic staff in higher education. *Quality Assurance in Education*, 4(3), 11-16.
- Rowley, J. (2000). Is higher education ready for knowledge management? *International Journal of Educational Management*, 14(7), 325-333.
- Ryan, R. M., & Deci, E. L. (2000). Intrinsic and extrinsic motivations: Classic definitions and new directions. *Contemporary Educational Psychology*, 25(1), 54-67.
- Sajeva, S. (2014). Encouraging Knowledge Sharing among Employees: How Reward Matters. *Procedia-Social and Behavioral Sciences*, 156(2014), 130-134.
- Shanshan, S. (2014). A Comprehensive Relational Model of Factors Influencing Knowledge Sharing: An Empirical Study. *International Journal of Knowledge Management (IJKM)*, 10(1), 1-25.
- Sharratt, M., & Usoro, A. (2003). Understanding knowledge sharing in online communities of practice. *Electronic Journal of Knowledge Management*, 1(2), 187-196.
- Sheppard, B. H., Hartwick, J., & Warshaw, P. R. (1988). The theory of reasoned action: A meta-analysis of past research with recommendations for modifications and future research. *Journal of Consumer Research*, 15(3), 325-343.
- Siddique, A., Aslam, H. D., Khan, M., & Fatima, U. (2011). Impact of academic leadership on faculty's motivation, and organizational effectiveness in higher education system. *International Journal of Business and Social Science*, 2(8), 184-191.
- Sita Nirmala Kumaraswamy, K., & Chitale, C. M. (2012). Collaborative knowledge sharing strategy to enhance organizational learning. *Journal of Management Development*, 31(3), 308-322.
- Slocombe, T. E. (1999). Applying the theory of reasoned action to the analysis of an individual's polychronicity. *Journal of Managerial Psychology*, 14(3), 313-324.
- Smerek, R. E., & Peterson, M. (2007). Examining Herzberg's theory: Improving job satisfaction among non-academic employees at a university. *Research in Higher Education*, 48(2), 229-250.
- Sohail, M. S., & Daud, S. (2009). Knowledge sharing in higher education institutions: Perspectives from Malaysia. *Vine*, 39(2), 125-142.
- Stenmark, D. (2000). Leveraging tacit organizational knowledge. *Journal of Management Information Systems*, 17(3), 9-24.
- Sudirman, I. (2014). Dominant Factors Influencing Knowledge Sharing Among Employees at PT Inco Tbk Indonesia. *American Journal of Business and Management*, 3(4), 224-236.
- Susanty, A. I., Wardhana, A., Hidayatunnisa, D., & Auliya, N. (2014). Extrinsic and Intrinsic Motivation Influence Employees' Performance through Knowledge Sharing. Paper presented at the International Conference on Emerging Trends in Academic Research November 25-26, 2014, ETAR © 2014 Bali, Indonesia.
- Sutton, M. (2006). Knowledge citizen's approach to knowledge sharing, rewards and incentive. *American International Journal of Contemporary Research*, 8(3), 138-147.
- Tan, T. H., & Waheed, A. (2011). Herzberg's motivation-hygiene theory and job satisfaction in the Malaysian retail sector: The mediating effect of love of money. *Asian Academy of Management Journal*, 16(1), 73-94.

- Tohidinia, Z., & Mosakhani, M. (2010). Knowledge sharing behaviour and its predictors. *Industrial Management & Data Systems*, 110(4), 611-631.
- Vera-Muoz, S. C., Ho, J. L., & Chow, C. W. (2006). Enhancing knowledge sharing in public accounting firms. *Accounting Horizons*, 20(2), 133-155.
- Wah, C. Y., Menkhoff, T., Loh, B., & Evers, H. D. (2007). Social capital and knowledge sharing in knowledge-based organizations: An empirical study. *Knowledge Management, International Journal of Knowledge Management*, 3(1), 29-48.
- Wang, S., & Noe, R. A. (2010). Knowledge sharing: A review and directions for future research. *Human Resource Management Review*, 20(2), 115-131.
- Wasko, M. M., & Faraj, S. (2000). "It is what one does": why people participate and help others in electronic communities of practice. *The Journal of Strategic Information Systems*, 9(2), 155-173.
- Wei Chong, C., Yen Yuen, Y., & Chew Gan, G. (2014). Knowledge sharing of academic staff: A comparison between private and public universities in Malaysia. *Library Review*, 63(3), 203-223.
- Welschen, J., Todorova, N., & Mills, A. M. (2012). An investigation of the impact of intrinsic motivation on organizational knowledge sharing. *International Journal of Knowledge Management (IJKM)*, 8(2), 23-42.
- Ye, N., Zhi-Ping, F., & Bo, F. (2005). Motivation factors that make knowledge workers share their tacit knowledge in universities: An empirical research. Paper presented in *International Conference on Services Systems and Services Management*, (Vol. 2, 923-927).
- Yeon, K., Wong, S. F., Chang, Y., & Park, M. C. (2015). Knowledge sharing behavior among community members in professional research information centers. *Information Development*, 30(3) 1-18.
- Zoubi, D. M. (2009). Knowledge management awareness and its related operations and their impact on knowledge management utilization at jordanian universities. *International Journal of Knowledge Management (IJKM)*, 5(4), 60-84.

FIRST YEAR NURSING STUDENTS' VIEWS ON ELECTRONIC FORMS OF TRAINING

ANGELINA KIRKOVA

KRISTINA KILOVA, TEODORA DIMCHEVA, YORDAN MARCHEV*, ZHIVKO PEYCHEV, ANTONIYA YANEVA,
NONKA MATEVA

Department of Medical informatics, Biostatistics and e-learning, Faculty of Public Health, Medical University-Plovdiv, Bulgaria

*Specialty "Radiolaboratory Assistants", Medical College

ABSTRACT

Electronic forms of training are widely spread nowadays even in traditionally conservative specialities as is nursing. Pregraduate nursing training comprises three levels – theory education, practical training in laboratories and clinical training at the patient's bed. Electronic forms can be used in all three levels with different purposes and frequencies. Nursing is a humanitarian domain and nursing students are not so technologically minded as their colleagues in science and engineering specialities. Faculty should take into consideration students' attitudes when designing e-learning forms and methods for nursing education. The present study deals with investigation of first year nursing students' views on electronic forms of training.

The aim of the study is to reveal the students' attitudes to e-learning in pre-graduate nursing training. An anonymous inquiry is carried out in December 2017 among 44 first year students from the Faculty of Public Health at Medical University – Plovdiv. The students were surveyed after completing an e-course in Medical Informatics supplementary to the face-to-face teaching, published on the e-learning site of the university. The e-course consisted of passive resources – lectures and presentations and activities – assignments, tests and interactive lessons. The participants were given ten statements and were asked to mark their agreement on a five-point Likert scale. The results are given as mean value and standard deviation of the level agreement on each statement in Table 1.

Table 1. Levels of agreement with statements about electronic forms of training

<i>Statement</i>	$\bar{x} \pm STD$
I am computer literate enough to cope with e-learning.	4.14±1.091
Interactive e-lessons are more suitable for self preparation than passive resources.	4.36±0.865
This e-course is enough for distant learning.	4.12±1.179
Some subjects can be taught distantly.	4.20±1.047
Some themes can be taught distantly.	4.52±0.952
Availability of e-learning makes time management easier.	4.66±0.608
Accessibility of e-learning helps saving finances.	4.61±0.784
The possibility to study where convenient leads to a low level of stress.	4.57±0.873
E-learning helps developing skills for long life learning	4.45±0.951
E-learning is applicable in my speciality.	4.21±1.036

The results indicate high levels of agreement on all ten statements. The students feel confident in their computer skills, which guarantees effective learning. They evaluate active forms as more useful for self preparation and it is a signal to teachers to devote time and effort to developing active learning. Students demonstrate readiness for distance learning, although in Bulgaria it is not regulated for healthcare specialities. The future nurses appreciate the key characteristics of e-learning – availability and accessibility. The statements which investigate attitude to these characteristics have the highest levels of agreement. Our students are aware of the long life learning perspective and the role of e-learning in it and they have a positive attitude to the implementation of electronic forms of training in nursing education.

Keywords: e-learning, nursing students

FAMILIES WITH HANDICAPPED CHILDREN: A QUALITATIVE RESEARCH ON PARENTS' EXPERIENCE REGARDING THEIR (OTHER) NORMALLY DEVELOPED CHILDREN

ASNAT DOR AMANI SHIBLI

PhD, Department of History, Kaduna State University, Tafawa Balewa Way, Kaduna-Nigeria

ABSTRACT

Background: The purpose of this study is to learn closely on families with handicapped children and to focus on the experiences of parents regarding their coping with their normally developed children.

Participants:

Twenty parents (17 mothers) from north of Israel who had at least one child age 4-21 with a severe disability (such as mental retardation, severe autism) and who had at least one more child who is normally developed.

Research tools:

Semi-structured interviews were carried out to capture parents' experiences and perceptions. Transcripts were analyzed by using a directed approach to the qualitative content analysis.

Results

The parents describe a significant and demanding coping in 4 major dimensions: Emotional, Cognitive, Social and Behavioral. The family's needs are constantly evaluated by the parents who have to take under consideration the needs of the handicapped child, many times on their own expense and that of their healthy children.

Conclusions and implications for practice

Parents are constantly coping and facing stress in a high level of intensity. Support systems are crucial to their daily functioning. Feelings such as loneliness, heavy burden and overload must be addressed by policy makers in the process of accompanying these parents throughout their challenging upbringing of their children.

Keywords: handicapped children, normally developed children, parental coping

Asnat Dor is a senior lecturer in Emek Yezreel Academic College, in Israel. She teaches in the school counseling master degree program, in the department of Education. Her main research topics are parenting research.

QUALITATIVE EXAMINATION OF THE PERSPECTIVES OF PARENTS WITH GIFTED CHILDREN ON MATHEMATICS EDUCATION

AVNI YILDIZ
SERDAL BALTACI, CAHIT AYTEKIN

¹ Asst. Prof. Dr., Bulent Ecevit University, Ereğli Faculty of Education,
Elementary Mathematics Education Department, Ereğli, Zonguldak, TURKEY

^{2,3} Assist. Prof. Dr., Ahi Evran University Faculty of Education,
Elementary Mathematics Education Department, Kırşehir, TURKEY

ABSTRACT

The countries that consider the future should pay attention to the gifted education. As a matter of fact, studies for the gifted education are gradually increasing. In this study, it is aimed to qualitatively examine the expectation of the gifted student parents about mathematics education. Therefore, it is considered that useful information can be reached for our education system at the end of the research. The research question was determined as “What is the perspective of the parents with gifted children on mathematics education?”. The research was designed as a special case study. The sample of the study was determined by the maximum diversity method. Six parents who have gifted children in a secondary school were included in the research. Before conducting the research, a certain period of time was spent with the parents and they were informed about the purpose of the research. Semi-structured interviews were also used in collecting the data. Data were analyzed using the content analysis method. According to the results of the research, it is determined that the parents of the gifted students are expecting more activities based on the conceptual meaning. In addition, it was observed that parents were expected from teachers to use computer software based on three-dimensional visualization. Because these kinds of software allow children to immediately see the changes what they think. Usually the mothers have stated that gifted children should not be shown authoritarian behavior.

This result is consistent with the literature that the gifted students do not like authority and rule-oriented teaching.

Keywords: parents of gifted students, expectation from mathematics education, opinion

Acknowledgement: This presentation is a part of the research project supported by Ahi Evran University with the project number EGT.A3.17.012.

I. INTRODUCTION

In the 21st century technology, the importance of knowledge is rapidly increasing and accordingly the concept of "knowledge" and "science" are changing, and the skills that society expects from individuals are also changing (Rogers, 2003). Therefore, the education given to gifted students has become even more important today with these expectations. Thus, the countries that consider the future should pay more attention to the gifted education. As a matter of fact, studies on the gifted education are gradually increasing.

It is an inevitable reality that gifted students have different abilities. Miller (1990) noted that gifted students in the mathematics have mastered skills in the processes such as organizing material, using rules, changing the expression of the problem, using new expressions, understanding and manipulating very complex issues, and reversing operations. Sowell, Zeigler, Bergwell and Cartwright (1990) also stated that gifted students are able to demonstrate mathematical skills which can be done generally by older students. Gifted students are characterized by their abilities to pay continuous attention to problem solving (Johnsen, 2004). Thus, gifted students should be given different sources of activities rather than giving unnecessary repetitions like other students (Meyen & Skrtic, 1988).

As mentioned above, when examining the features of both 21st century and gifted students, there has been a significant change in the way of looking at mathematics education in recent years in order to educate gifted students. In the process of these changes, mathematics education aims to educate people who do not only know mathematics but also apply the knowledge they have, do mathematics, and solve problems (Broudy, 1982; Charles & Lester, 1982). In order to achieve these goals, there are great responsibilities, especially for the families of gifted students.

Parents' participation in students' education increases their academic success and supports their positive behavior and emotional development (Booth & Dunn, 1996). Without a difference in socioeconomic level, students whose parents are actively participated in their education generally obtain higher grades, attend higher education, regularly attend school, and develop faster social skills (Cai, 2003; Hatch, 1998; Henderson & Berla, 2004; Nyabuto & Njoroge, 2014; Schickedanz, 2003). In his study, Schickedanz (2003) found that the students whose parents have limited participation in education showed low academic performance. Jaynes (2005) also emphasized that studies on the role of the family in teaching are very limited and

insufficient so that the research should be done in more detail. In this context, it is important to reveal what gifted student parents expect from mathematics education.

Eccles and Harold (1993) classified the forms of participation of parents in education under five categories. In this classification, the first level parents were only the audience, and the fifth level parents, who are the highest level, were constantly communicating with teachers and school administration, spending extra effort for the development of their children, and following their children's daily efforts and progress. Similarly, Cai, Moyer, and Wang (1999) defined five different parent roles according to their contributions to their children's mathematics: motivational, audience, resource provider, supportive, and advisor. They stated that the parents in the supportive and advisor roles help their child in the home.

There are various studies in the literature that examine parents with various variables such as socio-economic level, education level, level of participation in mathematics education, and level of interest in the mathematics (Kotaman, 2008; Phillips, 1998). In this study, the researchers provide useful information to the literature since this study was aimed to qualitatively examine the expectations of the gifted student parents about mathematics education. For these reasons, the research question was "What is the perspective of the parents with gifted children on mathematics education?"

2. METHOD

The following section covers the research model, research group, data collection, and data analysis.

2.1 Research Model

The special case study method was used in designing this research because it is essential to examine a certain group in depth.

2.2. Research Group

The maximum diversity sampling was used in determining the participants of the research, which is one of the purposeful sampling methods. Because qualitative work is usually done with fewer people and there is no purpose of generalizing the results (Patton, 2005). For this reason, six parents who have gifted children of secondary school were included in the research. When choosing these parents, the achievements of gifted students were taken as reference and these

achievements were collected in three categories. For each category, one mother and one father were taken.

2.3. The Data Collection Tool

Before conducting the research, a certain period of time was spent with the parents and they were informed about the purpose of the research. Subsequently, each of the interviews with the parents was recorded with a digital voice recorder with the permission of the parents. Each interview took approximately one hour. Inferences were submitted to the participants in order to prevent misunderstandings.

2.4. Analysis of the Data

The data of the obtained research was analyzed by content analysis from qualitative data analysis methods. Before analyzing, the data obtained from the interviews were transcript and checked. During transcript process, each interview was written exactly as they were without any corrections. Researchers analyzed the data independently from each other, and then, the analyses were combined and compared. During the analysis of data, mothers are encoded as M₁, M₂; fathers are encoded as F₁, F₂. Inter-encoder reliability coefficient consistency index was calculated as 0.91.

3. FINDINGS

When the results were analyzed, it was determined that the participants were expecting activities based on conceptual understanding. As an example of this process, the expressions of M₁ and F₂ are as follows.

M₁. I want my child to understand the mathematics exactly. I mean, I do not want my child to memorize math, just like verbal lessons, do not read it. I want my child to look around himself/herself about how mathematics in life. Maybe he can learn more differently. Or learning math with games is more memorable. These are just my thoughts. Because my child can not cope with tough conditions. I think it is necessary to teach mathematics by making love and grasping the true meaning of mathematics.

F₂: My child is reading a lots of books. I'm aware of his capacity. But I want my child to have good math lessons, but I never pressure him. For example, he is trying to give different examples while telling him a different subject. The fact that he can express something by himself makes me happy inside. For this reason, the meaning and nature of the concepts should be mentioned in the lessons.

Therefore, it was observed that parents were expected from teachers to use computer software based on three-dimensional visualization. Because these kinds of software allow children to immediately see the changes what they think. For example, M₂ and F₃ parents say they are pleased that when their gifted child show them what they see on their computer screen as follows.

M₂: For example, one day he showed something on his computer screen. This was sometimes math software that teachers used. I do not remember the name, but when I showed it to me; I saw that this program affected him. I think it is more useful to show it in this way than to draw in the book. It's quite important to be three-dimensional. It is difficult to explain these illustrations by drawing. The most important thing is that it will become difficult to understand. That's why it's a good lesson.

F₃: My child's teachers were using computer very often in mathematics lessons. My child also had a curiosity about the computer. For example, when I saw my child on the computer screen, I thought what I was doing with the computer. Actually, at first I thought my child was playing a computer games. But when I see that he did something on the computer and wrote something in the notebook, I asked. He told me his teacher gave homework, he thought about it. I like it so much. Because there was some geometry on the screen and my child was working on it.

Usually the mothers have stated that gifted children should not be shown authoritarian behavior. This result is consistent with the literature that the gifted students do not like authority and rule-oriented teaching. For example, M₁, M₃ and F₂ parents stated as follows.

M₁: My child does not study with pressure. my child can work very easily on his own. Sometimes I give him advice, but do not bother. So I do not force him especially in mathematics classes. He already loves mathematics. I'm afraid that this love will be reduced because of pressure. That's why I expect this from my mathematics teachers.

M3: I know my son very well. An authoritarian approach, especially in difficult subjects like mathematics, makes my child nervous.

F2: My child loves mathematics. There is a special interest, actually. I never put pressure on him. I don't want that teachers put pressure on him. Maybe he would not like mathematics so much if I did not do it like this.

4. **DISCUSSION AND CONCLUSIONS**

Some studies show that parents' education levels do not play a role on their children's academic success (Xu & Corno, 2003), some other studies (Kotaman, 2008) stated the opposite. But most research found a strong relationship between parents' expectations and their children's academic achievement. In the current study, it was determined that the participants were expecting activities based on conceptual understanding. If the expectations of teachers and parents are in harmony with conceptual understanding, this is a positive factor that promotes the gifted students.

Parents wanted from teachers to use more often the software allow three dimensional visualization, showing the changes immediately and making what they think. Rogers (2002) stated that there should be special classrooms for gifted students, and in this way, there could be a competitive environment as well as opportunity for sharing knowledge with their peers. Gifted students may think more creatively thanks to the functionality and practicability of the dynamic software. As Mainali and Key (2012) point out, students start to explore concepts as a result of using the dynamic software.

Many parents have stated that gifted children should not be shown authoritarian behavior. This may be a consequence of the fact that the gifted students do not like authority and rule-oriented teaching, as frequently stated in the literature. Ablard and Parker (1997) determined that the gifted students, whose parents were in an expectation of "Authority and Rule-Oriented Teaching," had negative attitudes towards mathematics education.

***Avni YILDIZ** is currently an assistant professor at the Department of Primary Mathematics Education. His research interests include teaching and learning of mathematics, technology integration in mathematics education especially focus on GeoGebra dynamic mathematics software, gifted students, problem solving and lesson study.*

***Serdal BALTACI** is currently an assistant professor at the Department of Primary Mathematics Education. His research interests include teaching and learning of mathematics, technology integration in mathematics education especially focus on GeoGebra dynamic mathematics software, gifted students, problem solving and lesson study.*

***Cahit AYTEKİN** is currently an assistant professor at the Department of Primary Mathematics Education. His research interests include mathematics and science integration, mathematics teacher training.*

References

- Ablard, K. E., & Parker, W. D. (1997). Parents' achievement goals and perfectionism in their academically talented children. *Journal of Youth & Adolescence*, 26(6), 651-667.
- Booth, A., & Dunn, J. F. (1996). *Family-school links: How do they affect educational outcomes?*, Hillsdale, NJ: Erlbaum.
- Broudy, H. (1982). What knowledge is of most worth. *Educational Leadership*, 39(8), 574-578.
- Cai, J., Moyer, J. C., & Wang, N. (1999). Parental roles in students' learning of mathematics: An exploratory study. *Research in Middle Level Education Quarterly*, 22, 1-18.
- Cai, J. (2003). Investigating parental roles in students' learning of mathematics from a cross-national perspective. *Mathematics Education Research Journal*, 15(2), 87-106.
- Charles, R., & Lester, F. (1984). An evaluation of a process-oriented instructional program in mathematical problem solving in grades 5 and 7. *Journal for Research in Mathematics Education*, 15, 15-34.
- Eccles, J. S., & Harold, R. D. (1993). Parent-school involvement during the early adolescent years. *Teachers College Record*, 94, 568-568.
- Jeynes, W. H. (2005). Parental involvement and student achievement: A meta analysis. Downloaded from: http://www.hfrp.org/publications.resources/browse_our_publications/parental-involvement-and-studentachievement-a-meta-analysis.
- Johnsen, S. K. (2004). Definitions, models, and characteristics of gifted students. In: S. K. Johnsen (Ed.), *Identifying gifted students: A practical guide* (pp. 1-22). Waco, TX: Prufrock Press.
- Hatch, T. (1998). How community action contributes to achievement. *Educational Leadership*, 55(8), 16-19.
- Henderson, A. T., & Berla, N. (2004). *A new generation of evidence: The family is critical to student achievement*. Washington DC: National Committee for Citizens in Education.
- Kotaman, H. (2008). Turkish parents involvement to their children's education. *Journal of Uludag University Faculty of Education*, 21(1), 135-149.
- Mainali, B. R., & Key, M. B. (2012). Using dynamic geometry software GeoGebra in developing countries: A case study of impressions of mathematics teachers in Nepal. *International Journal for Mathematics Teaching and Learning*, 16, 1-16.
- Meyen, E. L., & Skrtic, T. M. (1988). *Exceptional children and youth*. Denver, CO: Love Publishing.
- Nyabuto, A. N., & Njoroge P. M. (2014). Parental involvement on pupils' performance in mathematics in public primary schools in Kenya. *Journal of Educational and Social Research*, 4(1), 19-26.
- Patton, M. Q. (2005). *Qualitative research*. John Wiley & Sons, Ltd.
- Phillips, M. (1998). *Family background, parenting practices, and the black-white test score gap. The black-white test score gap*. Washington, D.C., Brookings Institution Press.
- Rogers, K. B. (2002). *Re-Forming gifted education: How parent and teachers can match the program to the child*. Great Potential Press Inc.
- Rogers, E. M. (2003). *Diffusion of innovations (Fifth Edition)*. New York: Free Press.

- Schickedanz, J. A. (2003). Family socialization and academic achievement. *Journal of Education*, 1, 17-34.
- Sowell, E. J., Zeigler, A. J., Bergwell, L., & Cartwright, R. M. (1990). Identification and description of mathematically gifted students: A review of empirical research. *Gifted Child Quarterly*, 34, 147-154.
- Xu, J., & Corno, L. (2003). Family help and homework management reported by middle school students. *The Elementary School Journal*, 103, 503-517.

EVOLUTION OF THE POLITICAL STATUS OF FEMALE RULERS IN ENGLAND IN THE X-XI CENTURIES

ANNA GOROKHOVA

EKATERINA NOSOVA

PhD, Associate Professors, Historical Faculty, Department of Ancient and Medieval History,
Moscow State Pedagogic University

ABSTRACT

The authors came to the conclusion the political status of English female rulers had strengthened by the end of X – beginning of XI centuries. The brightest example of that fact was the reign of Emma of Normandy who used her political influence in terms of the social standards of her day. Even in the period of her greatest power this queen positioned herself as a wife, a widow or mother of the legitimate monarch and was accepted by English society on these terms.

Keywords: Political status, female rulers, Emma of Normandy, Æthelred the Unready, Cnut the Great, English society

I. INTRODUCTION

In the early Middle Ages the king's wife is usually absent as a subject in male-dominated history in the sense that women as a rule can rarely be seen at those moments when decisions about war, peace and other major events were made. Historical sources generally reflect the male point of view in history. As Robert Fossier (2007) noted, historians were in thrall to the particularity of medieval sources for a long time (p. 91-95). This produced a quite paradoxical situation in which women were not taken into account by the majority of scholars. However, these female rulers belonged to the royal family and took an important place in the state hierarchy. For example, significant scholarly research has been devoted to Amulasuantha (486-536) the daughter of Theoderic the Great (486-536) and to Brunhilda (534-613), the wife of Sigebert.

Significant political and cultural changes happened in English society of the X-XI centuries. They transformed the main understanding of "male" and "female" as the main categories of the social order. Of course, traditional patriarchal views on the status of women dominated until modern times, but despite that, society adopted new ideas dictated by dynamic changes in political and cultural life. Gradually, the values of attitudes toward the status of women are refracted. In this context, the study of particular interest is the reign of Emma of Normandy, the wife of two English rulers Æthelred the Unready (978-1016) and Cnut the Great (1017-1035).

From the late X to the first half of the XI century there was an active centralization policy conducted by the English kings, accompanied by a noticeable strengthening of royal power. And the representation of the image of the king's wife underwent a significant transformation. For the first time in the sources there are references to the Queen's activities in the political and cultural life of the country.

Based on the surviving series of testimonies, including historical narrative, material and literary monuments, we will try to identify and determine the changes in the status of the king's wife through the example of Emma of Normandy. We will identify the role of Emma of Normandy in the political and cultural life of England on the basis of surviving historical narratives, Anglo-Saxon literature and official acts and decrees.

The research questions

In order to do that the following questions will be considered: what kind of woman should there be alongside the king? What functions and qualities should she have and how strong was her influence on the political life of England at the end of X and the beginning of XI century?

Methodology

The methodology of the research includes context analysis of the sources and spatial analysis with the help of which there is an attempt to identify the degree to which political influence of female rulers depended on the region where they reigned.

Main text

In the mentality of the inhabitants of Medieval England a good king had to be a good warrior. His wife, according to the social standards of the time had to have qualities connected with peace which can be traced in *Widsith* (1936) and *Beowulf* (1978) and also mentioned in the *Encomium Emmae reginae*, where she has a function of “*freoðuwebbe*”.

The poetic image of the Anglo-Saxon queens has been highlighted in recent research. This image includes some official functions such as mistress and donator. Recent research has underlined that in poetic representations Anglo-Saxon queens have been associated with official functions as homemaker and gift-giver. The queen also had responsibilities which were established by etiquette. She had to supervise the upbringing of her children and look after the royal throne on the death of the king.

In the *Encomium Emmae reginae*, one can find many similar lines. For example, Emma is given the role of peacekeeper. Thanks to her the military conflict between the Danes and the Anglo-Saxons was settled. According to the *Encomium* (1998) “... perhaps the war hardly ever ended, if not for the marriage union finally concluded with this noble Queen by the mercy of Christ” (II, 16-17). Emma also embodies the features of a loving mother who cares about her children.

If we turn directly to the political and legal sphere, it is important to highlight several important events that occurred in the mid-tenth century, which played an important role not only in the representation of the image of the queen, but also gave

legal levers to influence the political and cultural life of the country during the reign of Emma of Normandy.

Firstly, at the end of the tenth century, the king turns into "a person who is virtually inviolable". Consequently the status of the queen changed in the same way. The practice of female rulers signing royal charters, which appeared in Wessex in the X century, was gradually spreading. Most charters describe various land gifts and privileges to the church community and the aldermen.

Secondly, the turning point in the status of the king's wife was in the middle of the X century. King Edgar and his wife were crowned in Bath in 973, which set the precedent for the coronation of a queen in England. In the *Life of Saint Oswald* (1997) it is said that the queen was sitting among the abbots and the abbess. "She (the queen) ... was worthy to ascend to the royal bed, was a way of plenty ... when the marriage feast was over, everyone went home, favoring the king and queen, wishing them peace and prosperity" (p. 163). As we can see, the marriage ceremony is attributed to an important political and symbolic significance. Many contemporaries compared this wedding with the biblical story of the meeting of Solomon with the Queen of Sheba: "The queen was the image of the holy church of the whole Christian people ... the queen appeared on the right of You in a gilded outfit, clothed in the delights of many" (p. 340-341).

Thirdly, another important step in the changing political status of the female ruler was made in 973 in *Regularis Concordia* (1953, p.1-2). Since then a queen was an official patron of nuns, which also meant that the queen became closer to the sacral figure of the king. Another indicator of the growth of the political power of English queens was the cult of the Virgin Mary, which was developed in terms of church reform. The image of the Virgin Mary was carried over the Queen Mother in English society. A queen was also responsible for her children not only to care about their health and upbringing but also to reserve their right to the throne in case of the early death of the king.

Thus, by the time of Emma of Normandy's reign in 1002 in Anglo-Saxon society in certain spheres, thanks to legislation, realities of life and personal qualities, the king's wife was equal in rights, duties and opportunities with the king, which could sometimes be perceived by society as a deviation from the norms, but this deviation did not have negative connotations.

In 1002, Emma, the daughter of Count Richard of Normandy (943-996), arrived in England as the bride of King Æthelred the Unready. In the Anglo-Saxon Chronicle, she is respectfully referred to as a "lady." This marriage was of a purely political alliance, since the Normandy harbors were often used by the Scandinavians as a springboard for attacking the British Isles; it was only natural that Æthelred counted on a profitable military and political alliance with Normandy against Scandinavia, in particular against Denmark.

After the marriage with Emma of Normandy the sources highlight her elevated position in power beside her husband. Emma used all the privileges of queens, which she could use: she signed royal charters, patronized nunneries, distributed royal lands, took part in official royal ceremonies and so on. After her husband's death, Emma escaped with her sons to Normandy to save the life of the successors of Æthelred II.

In 1017, Emma became the wife of King Cnut, who included England in the Danish Empire. There is an interesting fact that Scandinavian invasions also influenced the status of the English queen, which partly contributed to the assimilation and revival of Germanic family and legal traditions.

In Scandinavia the political and legal powers of women are represented in family sagas and Kings' sagas and to a lesser extent in the legislation of the X-XI centuries. For example, Aud the Wise from the Laxdæla saga managed the household and was the head of the family, since her sons were still young. Droplaug in Droplaugarsona saga had the same functions. These sagas reflect the real practice of inheritance in the case of the absence of a male lineal heir or according to the desire of the owner of the property (in the event of his incapacity) the property could be inherited by a woman. It is also well known that some women accompanied their husbands on official trips, were warriors and fought on the battlefields next to their husbands. Konung's wife had an important political status. They could take decisions on the governance of the kingdom, call out troops and be intermediaries in negotiations.

According to the numerous charters signed by Emma, during the reign of Cnut, she not only strengthened her social status, but also significantly increased it. There are no other signatures in the charters, except for those of the king and queen. Sometimes official petitions of that time began with an appeal to both sovereigns.

Emma's responsibilities also included being present at formal receptions. For example, in 1023, the official ceremony of transferring the relics of the archbishop from London to Canterbury in the presence of the king, queen and high secular nobility took place (1998, XXXVI - a1012).

Emma also took an active part in church patronage, lavishly endowing the clergy with plots of land.

Thus, we see that Emma was a significant figure in the political and cultural life of the country.

Finally, the period of Emma of Normandy's greatest political activity came after the death of her second husband, which manifested itself in the confrontation between Harold (1035-1040) and one of her sons for fighting as a challenger for the English throne. The opportunity to be in the center of political events and decide the fate of the English throne was allowed to her not only by the status as widow of the deceased king, but also by the main status of the mother. In a few years, Emma would achieve her goal and raise her son Harthacnut to the throne.

Conclusion

In conclusion it can be said that Emma of Normandy used her political influence in terms of the social standards of her day. Even in the period of her greatest power this queen positioned herself as a wife, a widow or mother of the legitimate monarch and was accepted by English society on these terms.

References

- Robert Fossier (2007). *Ces gens du Moyen Age*. Paris: Fayard.
- Widsith (1936). *The Anglo-Saxon Poetic Records*/ ed.by. G.P. Krapp, E. Van K. Dobbie. – in 6 vol. – New York: Columbia University Press, 149-153.
- Beowulf* (1978). / ed. by M. Swanton.-Manchester, 612-613, 620-623, 2016-2017
- Encomium Emma Reginae* (1998). / ed. By A. Campbell.-repr.ed. – Cambridge: Cambridge University Press.
- Stafford P. (1997). *Queen Emma and Queen Edith: Queenship and Women's Power in Eleventh – Century England*. – Oxford: Blackwell.
- Ælfricð's Catholic Homilies, The First Series* (1997) / Ælfric: ed.by P. Clemoes. – Oxford: Oxford University Press.
- Regularis Concordia: The onastic Agreement of the Monks and Nuns of the English Nation* (1953) / ed. By T. Symons – London: Nelson.
- The Anglo-Saxon Chronicle* (1998) / ed. & trans. By M/ Swanton.- New York. Routledge.

EARLY CHILDHOOD EDUCATION TEACHERS' RECOMMENDATIONS FOR EFFECTIVE PROFESSIONAL DEVELOPMENT PRACTICES

GOZDE ERTURK KARA

Aksaray University, Aksaray University Faculty of Education Early Childhood Education Department
Adana Road Aksaray/Turkey

ABSTRACT

Aim of this research is to investigate early childhood education teachers' recommendations for effective professional development practices. Case study, one of the qualitative research methods, was preferred for this study. Study group consisted of three early childhood education teachers who work at preschools in middle Anatolia in Turkey. Semi structured interview form which was developed by the researcher were used during the focus group interview. Content analysis method was used to analyses the data. Data obtained from the focus group interview was examined according to following categories; school- university collaboration, from teacher to teacher education, multidisciplinary approach, parent- school collaboration and online support. School university collaboration category consists of the subcategories of academicians' role, seminars and teacher training programmes. From teacher to teacher education category consists of the subcategories of observer, focus group, regular meetings, volunteer, answerer role, encouragement and appreciation. Multidisciplinary approach consists of the subcategories of infollution, individual needs, phycology, nutrition and health. Parent school collaboration category consists of the subcategories of parent education, expectations, needs, aim of early childhood education, perceptual bias regarding teachers' role and infollution. And lastly, online support category consists of the subcategories of Pinterest, activities, creativity, multiple thinking, produce ideas, web page, secure, motivate to search and sources. In the light of the study findings, it is thought

that teachers' recommendations could be a lodestar for enhancing the current professional development practices.

Keywords: early childhood education, professional development, teacher recommendations

E-TESTS: PROS AND CONS EXPERIMENTAL STUDY ON ENGINEERING STUDENTS IN JORDAN

HASAN SHALABI

Faculty of Engineering, Al- Ahliyya Amman University, Jordan

ABSTRACT

Today internet has revolutionized the way education is provided; educators use computers and internet to teach classes, publish student's assignments that can be submitted directly by students or through the internet. E-Testing becomes more popular as a method of evaluating student's performance. Such a form of testing has its pros and cons. The purpose of this paper is to present the advantages and disadvantages of e-test as a method of student evaluation. These pros and cons were extracted from a survey that had been executed on the College of Engineering students at the Al- Ahliyya Amman University in Jordan. Also, the survey was extended to the staff members. This research with the help of continuous feedback aims to boost the positive aspects of the e-test procedures and reduce negative effects of e-test.

Keywords: online education, e- Tests, e- evaluation, internet in education, Pros and cons of E-Tests

I. INTRODUCTION

The term online is relatively a new concept. The development of Internet started in early 1990s. As part of this development, online courses become very attractive and common these days. Also, the availability of on-line access make it easy for students to study at home/work or any place/time utilizing communication tools, such as, computer, smart phones, social media...etc which is called online learning.

Online learning enrollment has shown a significant growth for the following reasons:

The majority of the students are choosing E-education to start and advancing in their careers while completing and furthering their education.

Financial crises had created poor economic situations where people are upgrading/changing their career through online educational/training programs.

The new method of education (E-Education) is not suitable for all students; however, it can be a highly effective method of education for the students who are matured, have a high degree of disciplined, self-motivated, and skills in time management. In the other hand, it is an unsuitable teaching for more dependent learners and has difficulty assuming responsibilities required by the E-Education.

Early 2000 studies indicate that more than 55 percent of employers generally accept the online learning. However, this was not the case with the students that they perceive the quality of online education better than traditional method. Other students expressed concern about employers' acceptance of online education, which prevent them to enroll in online courses.

Since there is significant growth in E-Education, it is important to consider the method of student evaluation. It is critical to consider both the pros and cons of E-Test that comes with On-Line method, the new opportunities that it has to offer, and that is its Strengths and Weaknesses. The next section is a good listing of these pros and cons of E-Test.

2. Classical versus online tests and assessments

2.1 Online tests and exams

2.1.1 Pros of Online Examinations

The main advantages of online examinations can be categorized into four groups:

- **Convenience**
- **Cost**
- **Technology**
- **Additional Benefits**

In addition, summarized as follows:

- **Convenience:** First of all the most obvious pro of an online education (e-test) is the convenience, and that's of course what attracts many people to it in the first place. With online education (e-test) you can learn about a subject, do e-tests/ assignments and get more information from the comfort of your own home and this is a great way to fit it around your own lifestyle. If you were to do night classes or attend a university then this would be hard to fit in around parenting or around a career, and make creates conflicts with the student schedule. Conversely with online education (e-test) you can take the test/assignments at your home, office or any location and you don't need to travel anywhere to do it. Depending on the course you may work to a deadline or you may even be able to complete each self-test/ assignment in your own time giving you the flexibility to really complete the course as and when you choose.
- **Cost:** The cost of an online education (e-test) may appears relatively higher than traditional education, however the final financial cost is significantly cheaper than what you'd pay for a full education, this cost saving make it easier for the students to afford obtaining a degree that was hard to achieve if it was through the traditional education Meanwhile you also make various other savings such as travel costs and more – and because you're able to work around education that means you can more easily fund it too.

- **Technology:** the advanced technology in computer, smart phones, pads and other communication tools make it easy to take the test and complete assignments at the location that the student find appropriate.

- **Additional Benefits:**

- **Less resource required:** Educational organizations conducting online tests require fewer resources. On the long run the cost of the infrastructure managing the classical tests is higher than the infrastructure need for online testing. The more students work via the Internet, the fewer students will use the physical campus facilities. This results in a reduction in, faculties, staffs, administrative personnel and operation expenses.

- **Offers access to students with disabilities:** A great advantage of online testing is its accessibility to students with disabilities. Computers can be customized to cater to those with various physical disabilities in order to place them on a level playing field with other students.

- **Easy Grading:** Giving grades for online tests is easier than the conventional way of examination and is time saving advantage for educators. Depending on the type of test given, instructors may be able to enter an answer key into the system once and instantly grade all incoming tests. Even on tests that require grading essay type questions, the submitted exams are organized and easy to read for quicker grading.

2.1.2 Cons of Online Examinations

The main disadvantages of online examinations can be summarized as follows:

- **Connectivity issues:** Connectivity can be a serious disadvantage of online testing. A student's internet connection at any location of on-line education can drop at any time for various reasons. In some cases this could cause the student to lose work or inadvertently submit tests that are incomplete.

- **Cheating:** The chances of cheating during an online test are tough to eliminate! In fact, unless an instructor is physically watching someone taking the test, it is almost impossible to mitigate.

- **Credibility:** Unfortunately online education is something that doesn't come with much glory. While some online education is very reliable and effective, not all online courses have that reputation and a few 'bad eggs' spoil it for the whole lot. At the same time even the best online

education isn't going to have quite the same respect as a degree or qualification from a college and that then means that when you show it on your CV you won't impress your potential employers in the same way specially in certain culture. Likewise you will get less respect from friends and family when you say it's an online degree (though of course you don't have to tell them). This depends partly on the reason you want to learn though and if it's just for your own enjoyment you may be fine with that.

- **Motivation:** You may find that if you learn from home then you don't feel as motivated to do it. This way it becomes something that you can put off until later and there's no one nagging at you. Likewise you'll find that you're surrounded by distractions like the TV and your family/partner. The internet especially social media is one of the biggest sources of distraction in the world. This can cause the unfortunate result of end up putting off your work indefinitely and as a result never completing the course that have been paid for – or alternatively completing it with minimum requirements.

- **Interaction:** Some online courses are highly interactive and will teach you through Skype, through online tests and through virtual lectures to recreate the feeling of being in a real classroom. However at the same time even these aren't as interactive as a living breathing person and you'll find that you suffer from not having someone to ask questions easily or other people around you to discuss the subject with. You miss out on a whole atmosphere of learning and that's a big deal.

- **Extract of Knowledge:** While it's useful being able to read up more on the areas you find interesting, this self-directed learning can also mean that you end up not having quite the same breadth of knowledge because you weren't forced as much to go through the boring basics or the areas you find dull. You'll also find that the hours you end up putting in are less as a result and that you read what you want and then goes away. This can make a difference to the kind of knowledge you have by the end and unlike a 'regular' course you won't have 'lived' it in the same sense.

2.2 From the other hand standard classical exams have their own advantages and disadvantages.

2.2.1 The main advantages of classical examinations can be summarized as follows:

- **Development of interpersonal skills:** When in a classroom, students are required to speak their mind. They are required to give presentations or speeches. They also have to work in groups with all kinds of people with many differing viewpoints. Online courses require none of that. Traditional style learning teaches these things.

- **Development of memory and learning:** While preparing for the traditional ways of examination, a student has to learn and has to memorize the teachings of the class. Doing this regularly develops their memory power and also enhances their ability to learn and imbibe the teachings fast and effectively. When someone does not have to study and memorize material, it does not embed in his or her long term memory the way it does when they do study it.

- **Motivates the students to learn:** One problem with online classes is that all too often, they motivate us to get a degree, but not to learn. When students receive face to face verbal feedback and constructive criticism from their professors, it instills in them a motivation to not want to let their professors down. It is the relationships and bonds that are formed that give face to face learning an advantage over online learning.

The main disadvantages of classical examinations can be summarized as follows:

- **A lot of resources required:** To conduct a traditional way of examination needs a lot of resources and capital investment. A physical campus, requirement of adequate faculty and study material, seating arrangements etc. are all mandatory for the traditional method.

- **Difficulty for the physically disabled students:** The physically disabled students have limited access to such traditional methods of educations and examination. Reaching the campus, writing the papers could be an obstacle for them.

With technological advancements and students getting computer savvy, they also want to adapt to the changes happening around them. The comfort of studying from home and doing it in one's own space makes the students take up the online examination. Besides, a lot of people take up the online education and examination to balance between their personal and professional responsibilities and education.

3. Experiment Results

In order to link the theoretical results and results obtained in different foreign countries with the Jordanian reality a questionnaire was conducted in Jordan.

3.1 Foreign Practical experiments

3.1.1 King Khalid University study

A practical study on the comparative analysis between the classical way of doing tests and the electronic testing was done in the University of King Khalid in the Kingdom of Saudi Arabia. The study aimed at two distinctive targets. The first target is to investigate how was the electronic testing developing through the years. It was revealed that electronic testing is rapidly infiltration the education system. Figure 1 shows how rapidly this process is taking place.

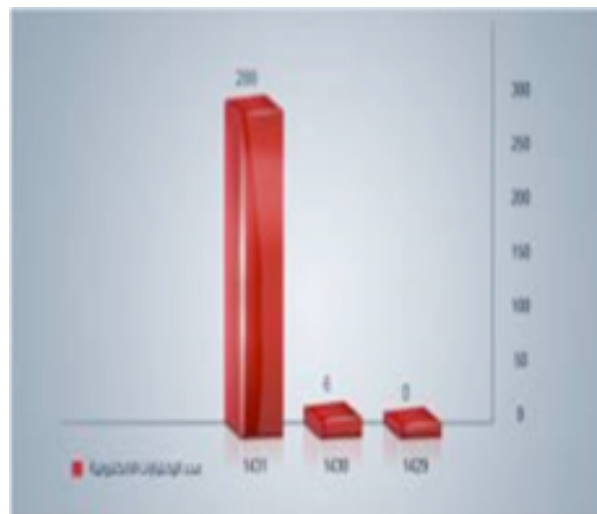

Figure 1

The second target was to do a comparative analysis between the infrastructure and cost invoked in each of these two systems for doing tests. The main findings in this study can be summarized in the table 3.1.1

steps	Traditional test	E-Test
Exam duration	44 hours	44 hours
Time correction	755 hours	0 hour
A correction reviewer	Yes	No
Corrector	Yes	No
Data entry	Yes	No
Error collection	Yes	No
lose examination paper	Yes	No

Table 3.1.1

3.1.2 NeenaNatt et al

In order to link the theoretical results and results obtained in different foreign countries with the Jordanian reality a questionnaire was conducted in Jordan.

In her paper “[Impact of electronic faculty evaluation on resident return rates and faculty teaching performance](#)” Natt compares between two ways of faculty evaluations: paper based and web-based. Paper-based evaluation systems require considerable administrative effort for data collection, analysis, archiving and dissemination of results to faculty in a timely manner. Replacement of a paper-based faculty evaluation system with a web-based evaluation system resulted in a dramatic increase in return rates. This study was carried out to determine the reason for the increase in return rates and the educational impact of faculty being able to access feedback data on their teaching performance electronically. Residents returned more web-based evaluations because of the convenience of the system and prompting by electronic reminders. Most faculty agreed that their electronic feedback data were useful to identify their teaching strengths and areas for improvement. Most faculty also perceived that they made minor to moderate changes in their teaching practices based on their feedback data. The most common changes were to increase bedside teaching and physical diagnosis, perform quicker rounds, provide more autonomy, deliver feedback and encourage self-directed learning. It is concluded

that an electronic evaluation system provides a convenient method to increase resident completion rates and hence the volume of data on faculty performance. A web-accessed electronic evaluation system is also a convenient method of providing feedback to faculty and may have a positive impact on teaching practices. Such changes in teaching performance can be monitored over time by faculty, program directors and accrediting bodies.

3.1.3 David Johnson Study

In this research the author compared between the classical tests and electronic tests. The study was carried on a sample of 150 American students. The whole sample was divided into two sub-samples.. The study revealed a huge advantage of electronic testing over classical one. Results of students performance was the main guide in the above mentioned conclusion.

3.1.4 Shudong Study

This research aimed at investigating the trends and future tendencies in electronic testing. It showed that electronic testing will be prevalent in the United States very rapidly.

3.1.5 Martin Study

This research was carried using a sample of medical students. The electronic testing included audio features. It showed very high acceptance among students.

3.2 Our Study

3.2.1 Experiment setup

The experiment consisted of a questionnaire distributed to a population of 300 engineering students. The questionnaire consisted of nine questions. The following is the list of the questions and statistics of the sample responses:

1) During your studies, did you have an e- Test?

Yes = 274 No=19 others = 7 ; others (no answer)

2) Did you find it difficult to perform the e- Test?

Yes = 76 No=208 others = 16 ; others (no answer)

3) The e - Test has reduced the anxiety and stress of the exam?

Yes = 127 No=92 others = 81 ; others (no answer)

4) Have you already trained on this type of test through an experimental test?

Yes = 51 No=237 others = 22 ; others (no answer)

5) Is the e- Test system easier for you to evaluate your performance than the traditional system?

Yes = 251 No=42 others = 7 ; others (no answer)

6) Does the e- Test accurately measure all the skills you have learned?

Yes = 139 No=89 others = 72 ; others (no answer)

7) Is the direct feedback of the e- Test useful increased the motivation of the student to improve their level?

Yes = 196 No=58 others = 46 ; others (no answer)

8) Is the electronic test presentation method satisfactory, interesting and clear?

Yes = 274 No=19 others = 7 ; others (no answer)

9) Do you support the dissemination of the idea of electronic testing of all subjects?

Yes = 264 No=13 others = 63 ; others (no answer)

3.2.2 Questionnaire Results

The results of the questionnaire are provided in figure 2

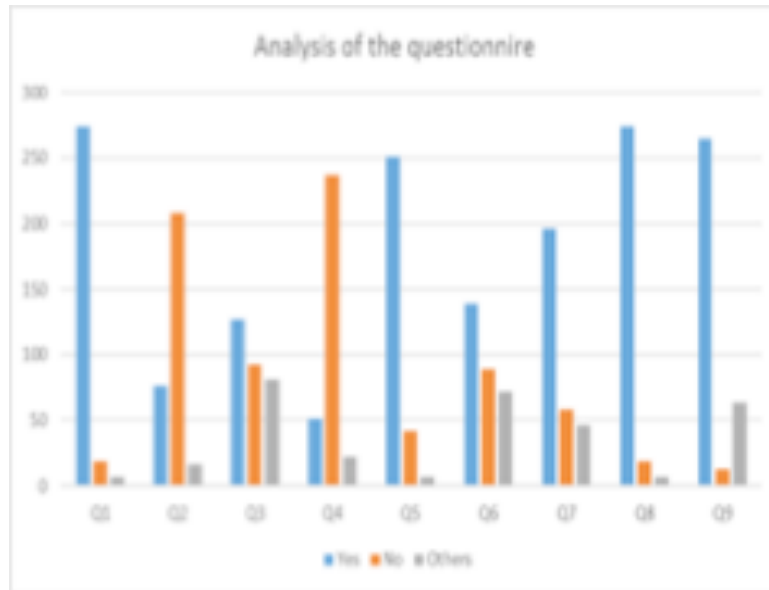

Figure 2

4. Conclusion

The facts are that there are advantages and disadvantages to every type of learning environment.

Students have to analyze both the pros and cons factors which contribute greatly to making an informed decision about the direction of his/her career path. Students have to decide, how they are going to accomplish their goals: online, in the classroom or a combination of both.

However, in some situations the inconvenience of maintaining a consistent school schedule prohibits potential students from furthering their education. It is also true that learning is highly dependent on the individual's motivation to learn. So the bottom line is that the efforts any student puts into their education that eventually determines how much he/she will retain and how beneficial the overall experience was to his/her future career.

References

Angus, S. D., & Watson, J. (2009). Does regular online testing enhance student learning in the numerical sciences? Robust evidence from a large data set. *British Journal of Educational Technology*, 40(2), pp. 255–272. Retrieved from: <http://onlinelibrary.wiley.com/doi/10.1111/j.1467-8535.2008.00916.x/abstract>

Gikandi, J. W., Morrow, D. & Davis, N. E. (2011). Online formative assessment in higher education: A review of the literature, *Computers & Education*, 57(4), pp. 2333-2351

Al-Shalabi, H., Swidan, A., Alrabea, A. and Senthil Kumar, A. (2012) V model of E-learning using gagne nine steps of education. *Journal of Software Engineering and Applications*, 5, 850-854. [ISSN Print: 1945-3116].

Al-Shalabi, H. and Al-Jufout, S. (2006) The electronic classroom through embedded e- learning in Jordan. *Asian Journal of distance education*, 3 (2): 42-47. [ISSN: 1347- 9008].

Al-Shalabi, H. (2005) Role of information technology for good governance and society. *Journal of Social Sciences*, Science Publications, 1 (2): 81-83. [ISSN: 1549-3652].

Hovland, E. (2005, March-April). Online testing - a look into the near future. *Media & Methods*, 41 (5), p. 13.

Karkee, T., Kim, D.-I., & Fatica, K. (2010, April-May). Comparability study of online and paper and pencil tests using modified internally and externally matched criteria. Paper presented at the annual meeting of the American Educational Research Association, Denver, CO.

Kerka, S., & Wonacott, M. E. (2000). Assessing learners online. ERIC Clearinghouse on Adult, Career, and Vocational Education: Practitioner File. Center on Education and Training for Employment, Columbus, OH. Retrieved from: <http://www.calpro-online.org/eric/docs/pfile03.pdf>

McLoughlin, C. & Luca, J. (2006). Best Practice in Online Assessment: Principles, Processes and Outcomes. In E. Pearson & P. Bohman (Eds.), *Proceedings of World Conference on Educational Multimedia, Hypermedia and Telecommunications 2006* (pp. 2375-2382). Chesapeake, VA: AACE. Retrieved from <http://ro.ecu.edu.au/cgi/viewcontent.cgi?article=3268&context=ecuworks>

POLITICAL IMPACT OF PUBLIC POLICY AS AN ACADEMIC DISCIPLINE IN NEW DEMOCRACIES: CASE STUDY THE REPUBLIC OF MACEDONIA

HRISTINA RUNCEVA TASEV

PhD, Assistant Professor, Faculty of Law "Iustinanus Primus" Skopje

ABSTRACT

New democracies, particularly post communist democracies, have faced many problems in the process of designing new institutions that restructure the role of the state in society. The challenge was how to build a distinction between institutions and policies: who governs and what governments do. In established democracies, institutions create and implement new policies, in new democracies the policies are focused on building new institutions. This process of transformation tested the democratic capacity of societies and was seen as a challenge for research by academics. Additional value to the complexity of this process was given by the cleavages in a society based on ethnic, linguistic, religious or political lines.

After institutionalizing Public Policy as an academic discipline at Political Science Department in the Republic of Macedonia, an environment for critical approach and theoretical resources has been created for public policy improvement. The deep ethnic and political cleavages in the Macedonian society created a complex power-sharing model where the institutional framework inherited from former Yugoslavia was not able to respond to policy making and implementation of different policy designs.

The paper aims to present the political impact of the Public policy studies as an academic discipline in a new democracy, such as the Republic of Macedonia, over the institutional framework on policy decision-making. In addition, the paper presents how the institutional

procedures interact with social and political circumstances in the country and the visibility of political impact in policy solutions in practice.

Keywords: public policy, political impact, institutions, Republic of Macedonia

SUPPORTING NEW LEARNERS AT UNIVERSITY: EMPLOYING DESIGN-BASED APPROACHES FOR 21ST CENTURY LEARNING

JENNIFER STOKES

University of South Australia

ABSTRACT

For graduates to flourish in the 21st Century, they require a combination of advanced knowledges and practices, including new literacies, creative, critical, ethical, and collaborative approaches, and a commitment to global citizenship (Binkley et al. 2012). For students who are new to the university environment, design-based approaches delivered in a technology-rich environment can support students to connect with university concepts, while building peer networks and skills for future success. Digital Literacy: Screen, Web and New Media and Future Ideas: Information and the Internet are two new courses designed and delivered at an Australian university, where they have received recognition for excellence in student outcomes, including a citation for Digital Learning.

This case study explores the application of Universal Design Learning (CAST 2011) and blended learning approaches in these two courses, in order to prepare and empower students for success at university and beyond. First delivered in 2015, Digital Literacy combines new literacies to foster student creativity, digital production and confidence in full participation in digital environments. Students analyse new media texts, pitch a concept, and develop innovative work, including apps, films, games, websites, augmented reality and virtual reality projects. A 2014 UDL audit resulted in the development of the Future Ideas course, where students conduct collaborative research, engage with ideas of collective intelligence through information systems, and gain greater learning outcomes through teamwork. A focus on real-world problem-solving combined with critical pedagogy (Freire 2004) and learning analytics has been used to create this course. Both

courses highlight the benefits of careful design and informed use of technology for inclusive education which prepares students with 'digital wisdom' for the challenges of the future (Prensky 2012). This case study offers insight into effective course design for new learners in the context of widening university participation and the need for engaging, technology-enhanced courses for millennial students.

References:

- Binkley, M, Erstad, O, Hermna, J, Raizen, S, Ripley, M, Miller-Ricci, M & Rumble M 2012, 'Defining Twenty-first Century Skills' in P Griffin, E Care & B McGaw (Eds), *Assessment and Teaching of 21st Century Skills*, Springer, Dordrecht.
- CAST 2011, *Universal Design for Learning Guidelines Version 2.0.*, Wakefield, MA.
- Freire, P 2004, *Pedagogy of hope: reliving Pedagogy of the oppressed*, Translated by R.B. Barr, Continuum, London.
- Prensky, M 2012, *From digital natives to digital wisdom: hopeful essays for 21st century learning*, Corwin, California.

VISUALIZE THIS: A VISUAL RHETORIC EXERCISE FOR STEM STUDENTS

JOSEPH WILLIAMS

PhD, Instructional Associate Professor, Texas A&M University at Qatar

ABSTRACT

Texas A&M University at Qatar (TAMUQ) is comprised of four engineering programs, namely Chemical, Electrical, Mechanical, and Petroleum. The engineering students who opted to take my Technical Communication & Rhetoric (TCR) course during Fall Semester 2017 embarked on a journey that involved the learning and analysis of effective document design. Alignment, balance, consistency, contrast, and grouping: Once the students mastered these principles of document design, they showed their skills by developing real world applications. The presenter, a Liberal Arts professor at TAMUQ, will share his findings as well as STEM student feedback that reaffirms the need to develop effective skills in Visual Rhetoric.

Keywords: Intercultural Communication, Findings

Dr. Joseph Williams currently teaches Freshman Composition, Technical Communication & Rhetoric, Intercultural Communication, Language of Film, and Literature and the Other Arts at Texas A&M University's branch campus in Doha, Qatar. Joseph previously served as a graduate exchange student to Bogazici University in Istanbul for two full semesters, where he cultivated his passion for Intercultural Communication. His academic interests include publications and presentations in the fields of Intercultural Technical Communication, Risk Communication, Applied Linguistics, Ethics, and Cyborgs among others..

THE BURGEONING OF TUTORING CRAM SCHOOLS IN TAIWAN AS SEEN FROM A DURKHEIMIAN SOCIOLOGICAL PERSPECTIVE

L.L.KUO

University of Edinburgh (alumna)

ABSTRACT

This research aims to uncover how underlying “social facts” as defined by Émile Durkheim, are associated with the increasing number of tutoring cram schools in Taiwan. In contrast to group-teaching cram schools, tutoring cram schools feature one-on-one teaching and have surged in popularity in recent years. Through semi-structured interviews with students in two tutoring schools based in Taipei, the researcher concludes that the tutoring cram school phenomenon is a reflection of several “social facts”, including a fear over employment uncertainty, the collectivism that is deeply rooted in Chinese culture, the Chinese approach to constructing “self” through competition, and the dramatic decline of the birth rate in Taiwan. Taken together, these factors intersect and contribute to the increased number of tutoring cram schools. Accordingly, they can be viewed as the social facts that create another social fact: the emergence of tutoring cram schools has given rise to a concrete social structure. Moreover, these foundational social facts function to categorize society members into different stratifications through educational institutions. This research concludes that education cannot be examined in isolation, but needs to be analyzed as part of a holistic picture that relates it to other social phenomena. As the tutoring cram school and the formal education system are both components of the social structure, suggestions for potential cooperation between both institutions to enhance educational quality are also provided in this paper.

Keywords: tutoring cram school, Émile Durkheim, social fact, social stratification, education

SOME ARAMAIC INSCRIPTIONS IN GEORGIA

MARIKA CHACHIBAIA

University of Edinburgh (alumna)

ABSTRACT

Some Aramaic Inscriptions in Georgia As a result of archaeological excavations carried out on the territory of Georgia inscriptions made in the Aramaic script were discovered. The paleographic study of these inscriptions, with an eye to the history or other realities make it possible to date them and determine the type and variety of the script. Some of the inscriptions are definitely nonAramaic linguistically, namely Iranian (non-aramaeographic) inscriptions. Due to the ideographic use of the Aramaic script, it is difficult to define the language of the text. Accordingly this difficulty is present when defining the language of the Arameographic texts in Georgia. The language of the other part of the Aramaic inscriptions is Aramaic. Three different types of the Aramaic writing are present in the Aramaic inscriptions discovered on the territory of Georgia: of the older period, specifically in the Hellenic time (3rd-2nd century B.C.), when the old Aramaic writing was used and the later one (1st-3rd century A.D.), the local type, created on the basis of the above Aramaic writing, the so-called Aramaic script and the so-called Parthian type created on the basis of the same old Aramaic script. Therefore the Aramaic and Parthian types proceed from the single protography of the same period and present the evolution of the old Aramaic writing, though these evolutions occurred independent of each other; the "Armazi" one in the Iberian-Armenian region via the northern Mesopotamia, and the Parthian in the vast Parthian Kingdom. Both the certain similarity and difference between the Parthian and "Armazi" scripts can be explained on the basis. This also explains their certain resemblance to the old Aramaic script. A very interesting picture of the use and evolution of the Aramaic script can be observed in Iberia and Armenia. In both countries these inscriptions basically belong to one and

the same period (1st-3rd century A.D.). Here it should also be noted that the writing of each monument is characterized by certain specific paleographic features. We cannot come across absolutely identical writing of one and the same letters not only in different "Armazi" texts, but sometimes they cannot be attested within the same texts either. Certain variations of identical letters in the "Armazi" script monuments are quite acceptable, but they are very rare and fall within the general limits of the script. Mention should be made of some violations from the viewpoint of the standard Aramaic grammar which are common for the Aramaic inscriptions of Georgian and Armenian Aramaic inscription. The problem of the language of the Aramaic inscriptions discovered on the territory of Georgia is most interesting. It is obvious that to say something about the minor inscriptions is very difficult: a couple of words cannot provide sufficient grounds to come to any conclusion. In this connection the "Armazi" stelae are of special interest of which one consists of eleven lines, and the other is fourteen-lined. From the very beginning the problem of the Aramaic text of the "Armazi" bilingual inscription was a contentious issue, but the thorough study of the bilingual text made it possible to explain "some linguistic irrelevance" from the viewpoint of the classical Aramaic.

ARCHITECTURE FOR PERSONALIZED ACADEMIC FEEDBACK

ANNETTE VAN DER MERWE
TINY DU TOIT & HENNIE KRUGER

North-West University, School of Computer Science and Information Systems, South Africa

ABSTRACT

The determinants for success in a module taken at a tertiary institution depends on different factors subject to the mode of delivery. The entities involved include the institution, faculty members and the learners. Achievement in on-campus teaching-learning is determined by the development of study material and assessments, instruction and facilitation by the lecturer, as well as student behaviour by attending contact sessions, studying and taking part in assessments. An increase in student enrolment numbers is being observed due to advances in e-learning, implementation of new teaching techniques, and financial assistance programs that are becoming more readily available to students. Nevertheless, universities struggle to increase their student retention rates. In an effort to prevent these rates from decreasing, this paper proposes an architecture aimed at providing students with information on their academic progress or lack thereof at regular intervals, and incentives towards improving their academic statuses. Existing studies on effective feedback are discussed briefly in order to establish the measurements by which the proposed architecture should be evaluated. The architecture is presented graphically and evaluated on the criteria established for improving the learning experience and preventing students from dropping-out. Results indicate that the architecture can be implemented in any module by incorporating it in a learning management system. It adheres to the requirements for effective feedback thereby promoting academic improvement, resulting in improved student retention.

Keywords: Academic feedback, feedback architecture, learning analytics, student retention

1. Introduction

In a traditional tertiary educational setting, lecturers present contact and facilitation sessions and use a combination of assessment techniques to calculate the grades that determine whether students pass or fail. Assessments can be formative (in the form of hand-written or electronic class assignments/tests, homework and practical assignments) and/or summative which usually happens at the conclusion of a semester/term in the form of an examination. Students are expected to actively participate in contact sessions, perform a certain degree of studying, and successfully partake in assessments for module completion. Among the actions that a lecturer is expected to perform, is the timely grading of assessments and corresponding feedback to students. This can be a very time-consuming activity that can unnecessarily compromise teaching quality, especially when student numbers are high.

In contrast, the future of tertiary education seems promising as an increase in student enrolment numbers is observed annually (Deen & Leonard, 2015). Several factors contribute to this, including an increase in programs being presented online (Naresh, et al., 2016), implementation of novel teaching techniques (Slechtova, et al., 2015; Sood, 2016) and financial aid schemes catering for specific student groups (Loyalka, et al., 2013; Vergolini & Zanini, 2015). However student drop-out rates have not decreased, in fact studies show that in South Africa 20% of students drop out in their second year and 25% in their third year of tertiary studies (Shay, 2017). Two of the reasons for this are that students do not appear to be properly prepared for the workload they encounter at tertiary level (Deen & Leonard, 2015) and the pace at which learning needs to take place is too steep (Du Toit, 2015). Although studies are being conducted on how to improve secondary education so that the level of preparedness for tertiary level improve (Deen & Leonard, 2015; Karabo & Natal, 2013; Shay, 2017), research into feedback methods that inform students how they are doing in their modules, also needs attention.

Feedback should ideally be given to students regularly and consistently in a semester so that they still have the opportunity to change and improve rather than dropping out later on. Another requirement is to provide students with more specific information or targets to reach towards improving their current academic standings (Van der Merwe, et al., 2017b). That means that with the increase in student enrolment numbers, lecturers still need to perform all of the tasks required from them and generate informative feedback frequently throughout the semester. Many studies have been done on assessment feedback which essentially provides a student with

real-time information during completion of an assessment (Evans, 2013; Stegmann & Malan, 2016; Wu, et al., 2016). This type of feedback is content specific and cannot be implemented generically in any random module. The issue of progress and improvement feedback therefore remains only partially solved.

The purpose of this study is to propose and develop an architecture for personalised academic feedback in an effort to assist with the problem universities are experiencing in terms of student retention. Existing methods of generating and providing feedback will be investigated in order to identify specific issues that need to be addressed. The architecture consists of models, algorithms and interfaces that can be implemented generically in any module.

The remainder of this paper is organised as follows. Section 2 contains a discussion on research related to progress feedback in an academic environment and issues that remain unsolved. This is followed by Section 3 wherein the criteria for evaluating the architecture proposed in this study, is discussed. Section 4 contains a description of the architecture design for personalised academic progress feedback. In Section 5, implementation of the architecture as part of a pilot study and evaluation according to the criteria established in Section 3, is discussed. The paper concludes in Section 6 with a summary and recount of the objectives reached in this study.

2. Related work

Due to the observed increase in student enrolment numbers in both online and on-campus settings, data processing and related progress feedback processes need to adapt so as to preserve the quality of teaching-learning. Implementation and evaluation of feedback in the educational environment is a widely researched topic (Martin-Chang, 2017; Nakata, 2015; Ryan & Henderson, 2017; Tempelaar, et al., 2015). Assessment feedback in particular is a popular subject especially in online learning environments (Evans, 2013; Webb & Moallem, 2016). Research on generic academic progress feedback methods that can be implemented in any required module however, is not readily available. Researchers agree that feedback in general needs to provide insight into how a student is doing, what the ultimate goal is, and steps to follow towards reaching the goal (Hattie & Timperley, 2007).

Towards finding techniques for student data processing into the required format for feedback, the feasibility of using mathematical modelling techniques as part of a learning analytics subsystem in a tertiary educational setting, was investigated (Van der Merwe, et al., 2017a). It was

found that the analytical processes required to generate feedback in the correct format can be performed by certain mathematical models. In terms of processing student progress feedback, a non-linear programming model was implemented to calculate what is referred to as a participation mark for each student. These marks represent the students' participation levels in the academic activities presented during a semester. Another method that was used to successfully perform academic peer ranking, was the dual formulation of a data envelopment analysis (DEA) model. This method allowed academic feedback to students in relation to their peers by using a class-ranking method (Kao & Lin, 2008), without the calculation of actual grades. The method also provided a means to calculate improvement targets for each individual student. The study addressed some needs relating to academic progress feedback but certain flaws were identified (Van der Merwe, et al., 2017a). Due to the non-linearity of the model utilised to generate the progress feedback, the solutions found were heuristic in nature and therefore did not guarantee optimality. Moreover, an exponential increase in the number of variables required for the dual formulation of the DEA was observed. Any change in student performance therefore meant a repeat of the solution process. The program selected to find solutions to mathematical models depended on the size of the problem. Large groups of students can therefore mean that a specialised software package is required to solve the model, which can have further financial implications. Another issue that was identified is the protection of student privacy which could not be guaranteed due to entire class lists being available to students.

The implementation of learning analytics principles in academic progress feedback presents the opportunity to address the problem relating to student privacy. According to Rubel and Jones (2016) the matters that need to be addressed to ensure that student privacy is properly protected include student access, data capturing, risk-benefit ratio of data processing and reporting, and student autonomy. Picciano (2014) asserts that precautions need to be taken when gathering, processing and reporting student data. To this end, student access to academic information needs to be regulated so that integrity is retained. Park and Jo (2015) found that students feel positively towards the use of dashboards which isolate their information. Such technology also encourages students to reflect on their own performance (Yousef, et al., 2015) which means that they are likely to respond to information such as improvement targets. Feedback presented in such a format can therefore have a positive influence on learning by encouraging students to modify their behaviour.

The problems that were identified in existing feedback systems include that they provide mostly content specific feedback during assessments, the processing methods are time-consuming and systems do not effectively protect students' privacy in terms of their grades. These issues were taken into consideration when developing the components of the architecture (Sections 3 and 4) and used as evaluation criteria to assess its success (Section 5).

3. Addressing the deficiencies in existing feedback methods

The criteria for successful feedback demand that the information be provided timely and consistently, be goal-specific, generically, personally and actionable (Hattie & Timperley, 2007). Existing feedback techniques partially cater for these measures but were found lacking in terms of time-optimised methods implemented to process student data and not providing sufficient information to enable improvement and protection of student privacy. These issues were set as the main requirements for the architecture developed in this study.

In general, the phases that need to take place in order for feedback to have a positive influence on an activity are data generation and capturing, data processing and formatting, feedback and behaviour modification (Wiggins, 2012). The entities required to perform these phases include the students who generate the data, receive feedback, and make changes to their behaviour; the lecturer who facilitate feedback and interventions; and a system to process and structure the data into the format required for feedback to be effective. Regarding the design of the system, a subcomponent implementing learning analytics techniques is utilised to combine the data processing and formatting actions required as part of the feedback architecture. There are three main areas of research in learning analytics namely instrumentation development, analytical methods and the effects of interventions (Roll & Winne, 2015). More specifically, learning analytics among other actions, include the analysis and interpretation of data related to student behaviour and contexts (Koç, 2016). With the incorporation of learning analytics tools however, more ethical issues regarding student privacy need to be addressed (Rubel & Jones, 2016). Special consideration needs to be given to who may be granted access to which student information and whether the collection and processing of the data lead to enhancement of the learning process.

The actions that have to be performed by the system are a combination of specific interrelated methods. In previous research it was found that non-linear programming and data envelopment analysis techniques failed to provide precise answers within an acceptable amount of time (Van

der Merwe, et al., 2017a). The mathematical models were consequently reformulated and solved in a related study (Van der Merwe, et al., 2017b). A linear programming model was implemented to generate student progress feedback in the form of their latest assessment grades and an academic student ranking which students could use to compare their progress with their peers. The academic ranking is a list on which the students are ranked according to their overall academic standings. The use of this model decreased the data processing time considerably, making it feasible to implement for timely and consistent feedback. Furthermore, an algorithmic approach was developed for improvement target calculation, which takes as input the solution of the linear model as well as a semester plan provided by the lecturer. A semester plan is unique to a specific module and typically consists of a time-dependent layout of the planned contact sessions and assessments for the remainder of a semester. The program automatically created a dynamic decision tree structure according to which all the possible scenarios for student participation in the sessions available for the remainder of the semester, were calculated. A user (student/lecturer) could nominate to what extent grade improvement is required and the system would use the student's current calculated academic standing and the developed decision tree to provide a proposal as to which future assessment participation should take place. The algorithm therefore provided personalised improvement targets per student as well as specific grades that students must achieve to guarantee improvement.

The discussed approaches will provide the information necessary to be classified as feedback and can be implemented in the system. However, each student's individual progress information needs to be available to that student alone as opposed to the entire class, as well as to the lecturer. Learning management systems (LMSs) are progressively being used for the implementation of specific learning analytical operations and serve as communication medium between students and lecturers (Ülker & Yilmaz, 2016). Such systems typically allow the users (students and lecturers) access to module content only if they are registered participants of that specific course. Appropriate regulation of access to personalised student data processed by the system, can be achieved by combining a LMS with an additional user authentication process.

In summary, there are three main components that must play a dynamic role in an architecture for personalised academic progress feedback that can be implemented generically (i.e. in any module). They are the students who are enrolled in the specific module, the system and the lecturer. Furthermore, the system should conform to the following requirements:

The methods used to perform the data analysis and feedback formatting processes must be time-optimised regardless of the number of enrolled students, so that reporting of academic progress can take place consistently;

Feedback must provide academic progress, personalised improvement targets related to each individual student's current progress and specific information on how to reach said targets; and

Student privacy must be protected by allowing each student sole access to their own personalised progress and improvement profile.

The architecture development according to the requirements stipulated above, is discussed in the next section.

4. Personalised academic feedback architecture design

Personalised academic feedback can be successfully achieved through implementation of the architecture shown graphically in Figure 1. The picture shows the three main components (student, system and lecturer) and how they relate to one another in the academic environment.

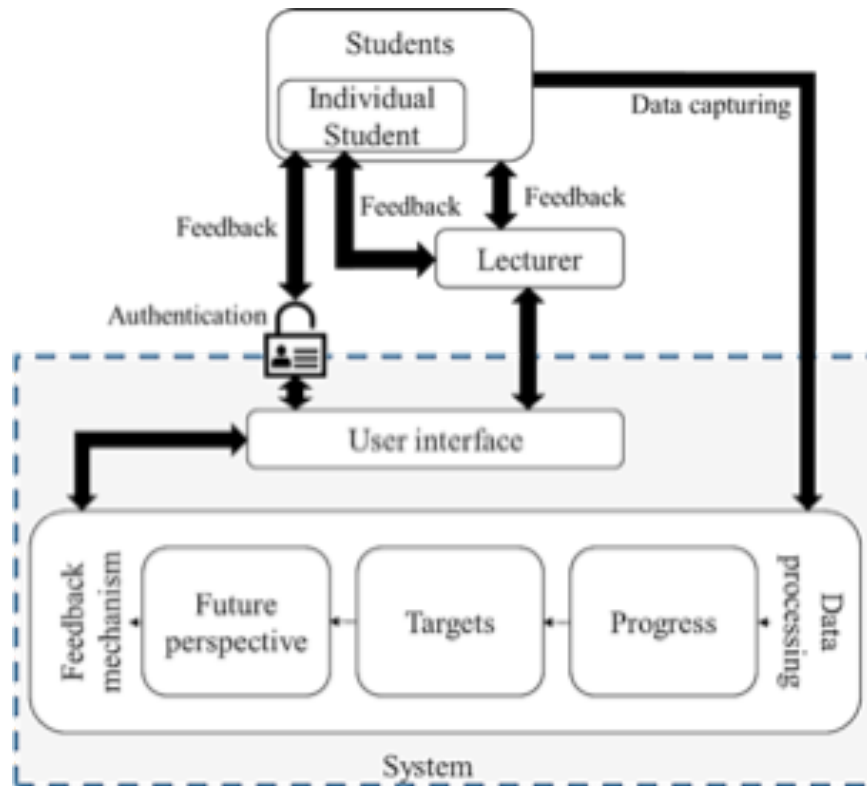

Figure 1: Architecture towards personalised academic feedback

The data generated by each student is captured in a traditional way through the completion of an assessment and the consequent grading. Student grades are imported into the system electronically and formatted using spreadsheet functions, into the correct format for processing. The methods discussed in the previous section are then implemented to process the raw data and prepare them for feedback. A user authentication system is incorporated into the system in the form of a graphical user interface, for use by individual students. This allows for each individual student to sign into the system and gain access to a personalised academic progress report and an academic ranking position without viewing or compromising the information of the rest of the class. The use of an authentication process effectively protects the privacy of each individual student. A lecturer is exempt from using the authentication process and have access to the progress profiles of the entire class. This enables a lecturer to determine which sections of the module content have not properly been mastered by reviewing the levels of student performance in specific topics.

The proposed architecture is independent of module content and can therefore be implemented generically to be used for any module in the academic environment. The methods discussed in

Section 3 are used by the system for processing and formatting into the correct feedback format. The techniques require no manual data processing and formatting to be performed by the lecturer, as this is done by means of a computerised system. Data processing and formatting is therefore optimised in terms of time. Feedback is formatted into the three required forms of information: it provides each student's current academic progress, it supplies interim targets to improve by a predetermined percentage, and it offers specific milestones to reach towards achieving those targets.

After a student logs into the system, the current academic progress is shown as in Figure 2.

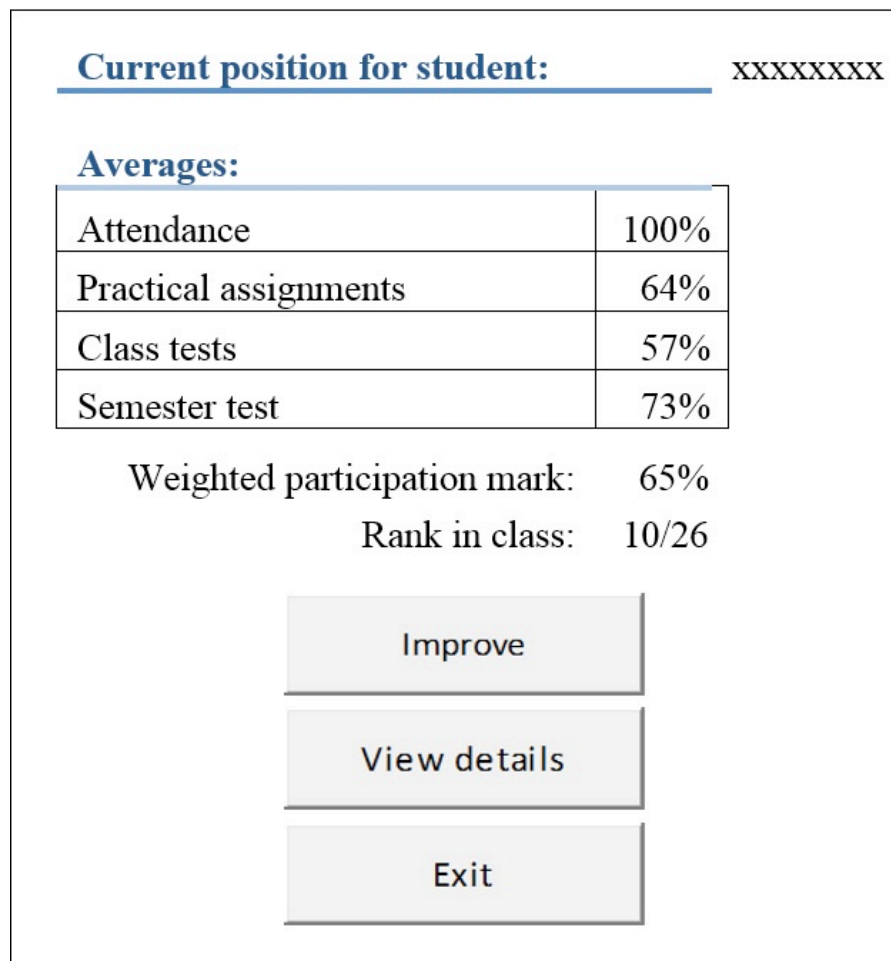

Figure 2: Academic progress page of a student

The current averages for each of the categories that the lecturer of the specific module grades (in this particular case attendance, practical assignments, class tests and a semester test), are shown.

This is followed by the student's current overall average (participation) mark of 65% and ranking position of 10 relative to the rest of the class. The average mark is calculated as the weighted sum of the average grades for the four named categories (1%, 33%, 33% and 33% respectively). The weights are selected by means of an algorithm that is discussed in detail in Van der Merwe et al. (2017b). The interface also provides the student with the option to view possible improvement targets and to view further details. By selecting the 'View details' option, the student will be provided with a more detailed layout of the grades of the individual assessments that have been completed towards obtaining the current progress profile (Figure 3).

Grades layout for student: XXXXXXXX

View grades for:

Semester test

Class tests

Practical assignments

Attendance

Display

Class tests:	1	2	3	Weighted average:
Date completed:	25/08/2015	22/09/2015	13/10/2015	
Grade:	38%	76%	30%	57%
				Ranking:
				10/26

Close

Figure 3: A typical detailed layout of the class test grades for a student

The information is provided per category, in spreadsheet format. If the student was to select the 'Improve' option (in Figure 2), the following plan will be displayed.

Improvement

Improvement calculated for: XXXXXXXX

Current averages:

Attendance:	100%
Practical assignments:	64%
Class tests:	57%
Semester test:	73%
Average participation:	65%
Current rank:	10/26

To improve your average by a target of: 5%

you need to complete:

	Required number of assessments:	Required grades:
Attendances:	4	100%
Practical assignments:	2	86%
Class tests:	1	77%
Semester test:	N.A.	N.A.

New average: 68.3%

OK

Figure 4: Improvement targets calculated for an individual student

The lecturer provided a semester plan at the onset of the semester which consisted of the planned number and types of assessments (attendance, practical assignments, class tests, and the semester test) for a specific module. The system used the semester plan to determine the remaining number of assessments in each category. Figure 4 shows a typical improvement plan for an individual student consisting of the current progress profile, followed by a targeted maximum improvement of 5% in the overall average, the number of assessments the student is required to complete in each of the relevant categories, the grades that the student is required to obtain in those assessments and the expected increase in the overall average as long as that all the named conditions were met. In this example, only one semester test was required for the module and at the time of producing the report, it has already been completed. The resulting improvement plan was therefore determined for the remaining three categories. Figure 4 shows that if the student completed four more

attendances with scores of 100% in each, two more practical assignments with an average score of 86% and one more class test with a score of 77%, then the new overall average will improve to 68.3% provided that the weights assigned to the categories remain unchanged (i.e. 1% for attendance, 33% for practical assignments, 33% for class tests and 33% for the semester test).

5. Evaluation of the architecture

The architecture presented in this paper was implemented in a pilot study, in three different modules at a tertiary institution. The system included a preliminary version of the user interface as shown in Figures 2 through 4. After assessment grading, the student scores were imported into the system and processed for feedback. The lecturers of the modules were given unrestricted access to the feedback which allowed them to act on information about at-risk students. The lecturers of the modules had access to the progress profiles of the entire group of enrolled students. They agreed that it provided valuable insight which aided them in early detection of students who were at-risk of dropping out. This enabled them to implement the measures considered necessary to assist such students. Additionally, they could also identify when specific module content has not been mastered satisfactorily.

The students actively used the feedback function of the architecture with 97% out of the 99 respondents indicating that they preferred to be informed of their progress at all times. A total of 90% of the students also indicated that they wanted the system to be implemented in all of their modules. Moreover, 85% of the students said that the feedback made them feel in control of their own progress (Figure 5).

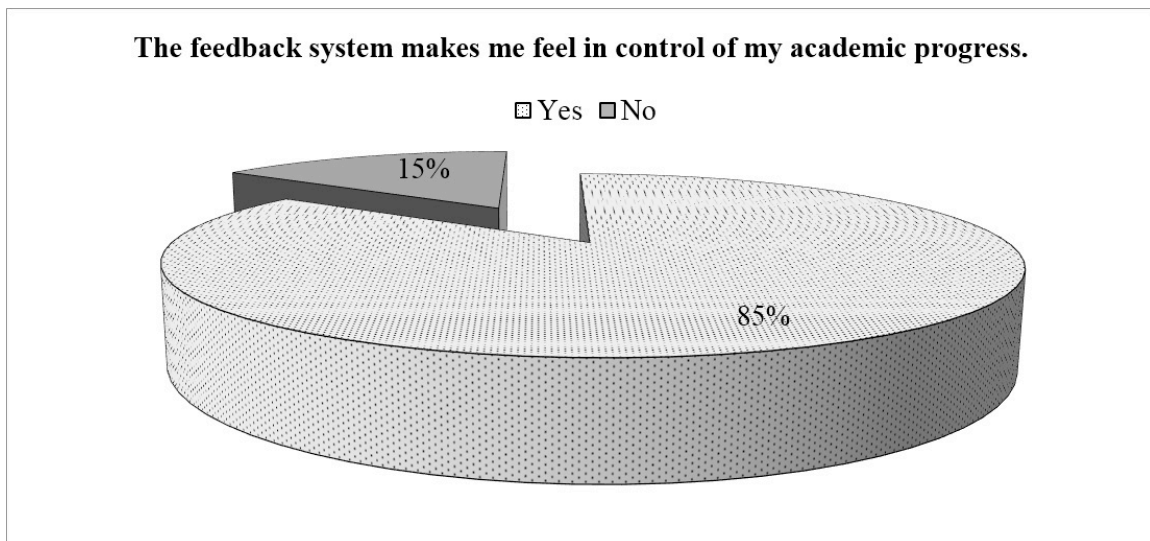

Figure 5: Student responses regarding control over their progress

Students furthermore showed a very positive attitude towards being able to monitor their progress (Figure 6). It is concluded that with the passing of time and the consequent decrease in the number of assessments remaining, some students believed that they had less control over what influence they could still have on their progress.

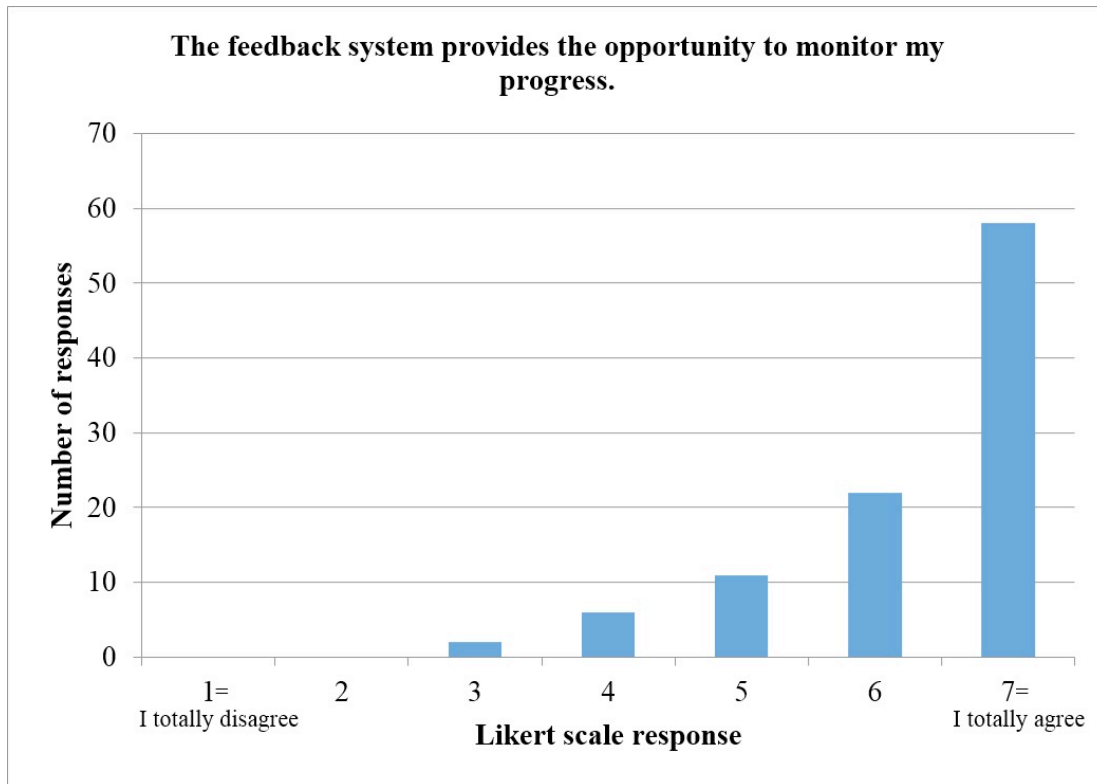

Figure 6: Student responses on monitoring their academic progress

Out of a total of 99 respondents, some 80 students regarded the feedback frequency (i.e. at every contact session) as acceptable and 85 indicated that they were satisfied overall with the system. Furthermore, only eight students thought that it was not important to know their academic progress throughout the semester.

The feedback provided to students adhered to the requirements for effective feedback as stipulated by Hattie and Timperley (2007) as outlined in Section 3. The additional criteria set in Section 4 were met as follows. The mathematical and algorithmic methods used for data processing and subsequent formatting into feedback are optimised in terms of time and feedback can therefore be provided consistently throughout a semester. The feedback given to students provide academic progress, personalised improvement targets related to each individual student's current progress and specific information of how to reach those calculated targets. Student privacy is protected through the use of the authentication system which provides each student with a personalised progress and improvement report.

6. Conclusions

The observed increase in student enrolment numbers in tertiary education environments due to various reasons has not resulted in increased student retention rates. Among several reasons for this phenomenon are that students do not seem to be prepared for the workload nor the pace at which learning needs to take place at tertiary level. Accordingly, lecturers are expected to continue performing the teaching tasks that are expected from them as well as additional administrative tasks towards enhancing learning. In this study, an architecture for personalised academic feedback was presented. The purpose of the architecture is to assist lecturers in the generation and provision of effective feedback that will inform students on their academic progress thereby affording better control over their studies.

A literature study was performed to establish the properties required for feedback to be effective. Requirements that needed to be addressed included incorporation of time-optimised methods that perform the data analysis and feedback formatting and that feedback must provide academic progress, personalised improvement targets related to each individual student's current progress and specific information on how to reach said targets. Another issue that needed to be addressed and that was added as an evaluation criterion for the architecture proposed, includes the protection of student privacy. The proposed architecture supplied feedback that conforms to the requirements to be effective and the system successfully addresses the discussed evaluation criteria. The architecture was presented graphically, after which it was implemented in three modules presented at tertiary level. It successfully protected student privacy and provided feedback that was timely, consistent, goal-specific, generic, personal and actionable. The students' positive reaction suggests that the architecture promoted academic improvement, which may result in improved student retention.

Students generally use learning management systems to gain access to academic material and module specific information while lecturers obtain valuable information gained from utilising learning analytics. Further development of the system is planned regarding improved student access by incorporating the system into a learning management system and allowing students to view their academic progress and improvement plans online.

Annette van der Merwe is a lecturer at the School of Computer Science and Information Systems at the North-West University in South Africa. She has a M.Sc. in Computer Science and is currently working on her Ph.D. in Computer

Science. She lectures in Expert Systems and Decision Support Systems is developing, implementing and evaluating mathematical models for use in educational applications.

Tiny du Toit is an Associate Professor in Computer Science and Information Systems at the North-West University in South Africa where he lectures in the subject of Artificial Intelligence. He obtained his M.Sc. and Ph.D. degrees in Computer Science at the North-West University and specializes in the automated construction of artificial neural networks.

Hennie Kruger is Professor in the School of Computer Science and Information Systems at the North-West University in South Africa. He has a Ph.D. in Computer Science, a M.Com. (Information Systems), a M.Sc. (Mathematical Statistics) and a M.Phil. (Philosophy). His current interests include decision modelling and Information Security.

References

- Deen, A., & Leonard, L. (2015). Exploring potential challenges of first year student retention and success rates: A case of the School of Tourism and Hospitality, University of Johannesburg, South Africa. *African Journal for Physical, Health Education, Recreation and Dance, Supplement 1* (December), 233-241.
- Du Toit, J. V. (2015). Using participation marks to manage, motivate and inform on academic progress. Conference for Outstanding Teaching/Learning and Innovative Technology Use. Potchefstroom, South Africa.
- Evans, C. (2013). Making sense of assessment feedback in Higher Education. *Review of Educational Research, 83*(1), 70-119.
- Hattie, J., & Timperley, H. (2007). The power of feedback. *Review of Educational Research, 77*(1), 81-112.
- Kao, C., & Lin, P.-H. (2008). Class ranking of the management colleges in Taiwan. *Lecture Notes in Management Science, 1*, 129-140.
- Karabo, M., & Natal, A. (2013). Factors influencing high dropout rates of girl child from education: A case study of black women in North West Province, South Africa. *Journal of Social Development in Africa, 28*(1), 111-138.
- Koç, M. (2016). Learning analytics of student participation and achievement in online distance education: A structural equation modeling. *Educational Sciences: Theory and Practice, 17*(6), 1893-1910.
- Loyalka, P., Song, Y., Wei, J., & Roselle, S. (2013). Information, college decisions and financial aid: Evidence from a cluster-randomized controlled trial in China. *Economics of Education Review, 36*, 26-40.

- Martin-Chang, S. (2017). Learning to read with and without feedback, in and out of context. *Journal of Educational Psychology*, 109(2), 233-244.
- Nakata, T. (2015). Effects of feedback timing on second language vocabulary learning: Does delaying feedback increase learning? *Language Teaching Research*, 19(4), 416-434.
- Naresh, B., Sree Reddy, D., & Bhanu, P. (2016). A study on the relationship between demographic factor and e-learning readiness among students in Higher Education. *Sona Global Management Review*, 10(4), 1-11.
- Park, Y., & Jo, I.-H. (2015). Development of the learning analytics dashboard to support students' learning performance. *Journal of Universal Computer Science*, 21(1), 110-133.
- Picciano, A. G. (2014). Big data and learning analytics in blended learning environments: Benefits and concerns. *International Journal of Artificial Intelligence and Interactive Multimedia: Special Issue on Multisensor User Tracking and Analytics to Improve Education and other Application Fields*, 2(7), 35-43.
- Roll, I., & Winne, P. (2015). Understanding, evaluating, and supporting self-regulated learning using learning analytics. *Journal of Learning Analytics*, 2(1), 7-12.
- Rubel, A., & Jones, K. M. (2016). Student privacy in learning analytics: An information ethics perspective. *The Information Society*, 32(2), 143-159.
- Ryan, T., & Henderson, M. (2017). Feeling feedback: students' emotional responses to educator feedback. *Assessment & Evaluation in Higher Education*, 1-13.
- Shay, S. (2017). Educational investment towards the ideal future: South Africa's strategic choices. *South African Journal of Science*, 113(1/2), 1-6.
- Slechtova, P., Vojacktova, H., & Voracek, J. (2015). Blended learning: Promising strategic alternative in Higher Education. 5th ICEEPSY International Conference on Education & Educational Psychology, *Procedia - Social and Behavioral Sciences*, 171:1245-1254. Jihlava, Czech Republic.
- Sood, S. (2016). Smart classrooms increase student enrolment in Ludhiana primary schools. *Hindustan Times*, December 12, 2016.
- Stegmann, N., & Malan, M. (2016). Accounting students' experience of an improved strategy of feedback on assessment. *Journal of Economic and Financial Sciences*, 9(3), 769-788.
- Tempelaar, D. T., Rienties, B., & Giesbers, B. (2015). In search of the most informative data for feedback generation: Learning analytics in a data-rich context. *Computers in Human Behavior*, 47, 157-167.
- Ülker, D., & Yilmaz, Y. (2016). Learning management systems and comparison of open source learning management systems and proprietary learning management systems. *Journal of Systems Integration*, 2, 18-24.
- Van der Merwe, A., Kruger, H., & Du Toit, J. (2017a). An early alert feedback system in learning. *International Conference ICT, Society, and Human Beings 2017*, 187-191. Lisbon, Portugal: Iadis.
- Van der Merwe, A., Kruger, H., & Du Toit, J. (2017b). Mathematical modelling for academic performance status reports in learning analytics. *ORiON* (submitted).
- Vergolini, L., & Zanini, N. (2015). Away, but not too far from home. The effects of financial aid on university enrolment decisions. *Economics of Education Review*, 49, 91-109.

- Webb, A., & Moallem, M. (2016). Feedback and feed-forward for proving problem-based learning in online learning environments. *Malaysian Journal of Learning and Instruction*, 13(2), 1-41.
- Wiggins, G. (2012). 7 keys to effective feedback. *Educational Leadership*, 70(1), 10-16.
- Wu, H.-M., Kuo, B.-C., & Wang, S.-C. (2016). Computerized dynamic adaptive tests with immediately individualized feedback for primary school Mathematics learning. *Educational Technology & Society*, 20(1), 61-72.
- Yousef, A., Chatti, M., Ahmad, I., Schroeder, U., & Wosnitza, M. (2015). An evaluation of learning analytics in a blended MOOC environment. *The Third European MOOCs Stakeholders Summit EMOOCs 2015*, 122-130.

THE REALITY OF PLACEMENT OF THE STRATEGIC ADAPTATION PROGRAMS BY KUWAIT UNIVERSITY LEADERS FOR CRISIS MANAGEMENT DURING THE ENVIRONMENT UNCERTAINLY

MEZNAH SAAD ALAZMI

FATMA SAAD ALHUBAINI

1) PhD, Assistant Professor, Dep. Of Educational Administration and Planning - College of Education Kuwait University.

2) Teacher- Ministry of education

ABSTRACT

This study aimed at identifying the level of investing the Strategic Adaptation Programs in Crisis Management during environmental uncertainty according to the faculty members in Kuwait university perspectives.. A descriptive method survey was employed in this study, it consists of three questionnaires. The first questionnaire is about strategic adaptation, and it consists of 21 Items. These Items were distributed in five categories: Human Recourse Program, Logistics Support, Policies Program, Strategies Program, and Information Technology Program. The second questionnaire is about Crisis Management, it consist of 8 Items. While the third questionnaire is about uncertain environment, it consists of it three Items. These Items include dynamism, threat, and diversification. The research sample consists of (n = 256) faculty members. For purpose of data analysis, appropriate statistical methods were used in the study. The study has concluded with the following results: (a) The perception regarding investing the Strategic Adaptation Programs in Crisis Management during environmental uncertainty were moderately. (b) There were significant statistical differences among the perspectives about investing the Strategic Adaptation based on years of service and academic rank. (c) There were significant statistical differences for the expectations of Kuwait University staff about the ability of the university to manage crisis based on the variable of years of service. (d) There were significant

statistical differences among the perspectives about the Crisis Management according to years of service. (e) There were significant statistical differences among the perspectives about uncertain environment based on type of faculty, years of service and academic rank. In light of this study some recommendations were reported, including: (a) There is a necessity of enhancing the concept of strategic adaptation in Kuwait University. (b) The decision-makers should depend on the scientific method in developing the capacity of workers in the University to be able for manage crisis.

THE INSTITUTIONALIZATION OF THE POLITICAL SCIENCE IN THE REPUBLIC OF MACEDONIA

MILENA APOSTOLOVSKA-STEPANOSKA

Assistant Professor at Public Policies, Political Studies Department, Law Faculty "Iustinianus Primus", Ss. Cyril and Methodius University, Republic of Macedonia

ABSTRACT

The countries of Southeast Europe, following the collapse of the Berlin Wall, have faced radical socio-political changes. The political system based on power-sharing, human rights, individualism, freedom of speech, market economy were new concepts for the citizens in these countries. Direct political speeches, demonstrations, pamphlets, free interviews, analytical articles and free communication between the government and the citizens were something new in the political setting. Apart from living these political changes, the Republic of Macedonia, at the same time, separated from the Yugoslav Federation and gained the status of an independent state. In this manner it is important to be said that in that time the social - humanistic science was fully focused on social transition that was taking place. In these circumstances, in 1993/1994, the first political studies at the Faculty of Law at the University "Cyril and Methodius" were formed. This university is the largest and the oldest in the Republic of Macedonia.

Since the establishment of the political science studies in the Republic of Macedonia, they were expected to give meaningful and practical implications and contribute to socially critical thinking and social reforms. There was an urgent need for improved understanding of certain social events. This urgency was reflected in the theoretical frame of certain social and political phenomena and their empirical monitoring. The main topics that become dominant on the classes were the basic ethical, political and economic pillars on which capitalism and Western democracy relies. At the same time dramatically rejection of certain theories that were previously dominant over the years happened and this can be seen after the analysis of the curricula of these studies.

The main aim of this research is to prove that the science in transition societies of the Southeastern Europe, including in the Republic of Macedonia was reflected by the development of the political environment in the society. This reflection is evident in the pronounced influence of the theory on account of empiricism, limited resources for empirical research, great and non-critical favoritism of Western theoretical thought, especially in the part of public politics.

Keywords: Transitional societies, Political science, Institutionalization

I. Introduction

All transition processes have something in common: they begin with the breakdown of an authoritarian regime, which is often equated with the first signs of mass mobilization for the end to finish creating a new system of governance who obtains legitimacy through democratic elections. From here many logical are the views of scientific community that any transition process should have a beginning and an end, but in the case of countries in the region, its fluidity, especially delineation phase, makes it particularly difficult.

However, completion of the elections and formation of new government in any a society that passes from the authoritarianism in a system with democratic values is not the end of the transition period. Change of the regime, however, involves changes in many other levels of the political system, especially in the processes of decision-making at central, regional and local level¹.

In that manner it is important to be stressed out that in the early 1990s new position and role of the science and education happened in the countries of Southeast Europe. They changed their socio-political system and entered a process of transition. Namely, there was a need for more effective and pragmatic science, free from ideological and political influences. This tendency was particularly visible in the social sciences.

This kind of positioning of the science was in direct correlation with the needs of the democratic and economic development. That is because the goals of the development are not only economic but also social and cultural².

¹ Zoran Filipovski, ``Transition Process In Southeast Europe And The Protection Of The Corpus Of Basic Rights And Freedoms`` International Refereed Scientific Journal Vision, Volume 2, Issue 1, March 2017, pp.23-30, http://visionjournal.edu.mk/wp-content/uploads/2017/07/irsjv_v2i1_zoran.pdf visited on 22.03.2018

² According to the expertise of a group of scientists (from different countries and scientific areas) engaged by the United Nations, the goals of development are not only economic but also cultural and social. According to them, the cultural development includes: science and technology, education, communications and other cultural activities (TV and radio, theater, cinematography, libraries, publishing). The new classification of natural and mathematical sciences, technical and technology, medical, biological, social and humanistic points to the directions of development, in particular the development pathways. Milorad D. Zakić, Methodology of Scientific Research and Development, Faculty of Law, Banja Luka 2000 p. 18.

2. Foundation of the political studies/political science in the Republic of Macedonia

The foundation of political sciences in the Republic of Macedonia begin with the opening of the faculty for political science within the Faculty of Law "Justinianus Primus" in Skopje in the distant 1993. Since then, many things have changed in terms of the structure of the curriculum and the number of students. After the opening of this Faculty of Political Science, three other political science faculties in Macedonia were opened: at the South East European University in Tetovo (Faculty for Public Administration and Political Science), American College - Skopje (Faculty of Political Science) and at the European University in Skopje (political science department within the Faculty of Law).

As a case study for this research the political studies from the Faculty of Law at UKIM will be subject of analysis, because those were the first open and later the other universities undertook the same tradition and curricula.

2.2 Development of the political science through the development of the curriculum

The constitution of the Republic of Macedonia in an independent country and the transition of the Macedonian society into a new social order inevitably implied the need for the introduction of the political studies as a new type of studies³.

Prof. dr. Savo Klimovski the founder and first Head of the political studies department in the monography titled "Historical development-Law faculty Justinianus Primus 1962-2005", wrote: "The development of the political studies was further stimulated by the need for the Macedonian political system to begin with a deeper analysis of the categories and values from the field of the democracy, civil society, liberalism, political parties and other issues and categories that were then introduced as new values in the content of our system⁴. The Faculty of Law saw this need and engage in active promotion of the scientific disciplines through which the Macedonian higher education system became active in the production of new highly educated professionals. Those professionals use their expertise and analytics and actively fit into the development of the democratic processes of the state following the example of the

³ Savo Klimovski, Development of the political studies curricula (1993-2005), "Historical development-Law faculty Justinianus Primus 1962-2005, book II, Law Faculty Skopje, 2011:42.

⁴ Ibid.

“old“ democracies⁵. Further more prof. Klimovski explains that that in the process of the foundation of the political studies they followed the examples and experience of the western universities but also the experience from the universities for political studies from Zagreb, Sofia, Ljubljana and Belgrade.

The fact that the political studies are within the Faculty of Law means that these studies are developed in the spirit and tradition of the legal studies, both in terms of human resources and content. Professors, assistant professors and assistants from the Faculty of Law are engaged in these studies. In the continuous process of modernizing the curricula, the European and world trends in the field of political science are taken into account. From the establishing of the political studies in the academic year 1993/94 the curricula has been changed four times but if we look better we can conclude that significant changes on the curricula have been made only once. Namely, the first curricula was established in 1993/94⁶ that can be seen in the table bellow.

⁵ Ibid.

⁶ The curriculum for political studies that was adopted included courses for four-years studies giving the students a slight focus in three narrower areas : political system, public opinion and mass communications and international political relations. This curriculum was composed of 22 compulsory and 3 elective courses.

I Year	II Year	III Year	IV Year
Political Theories I	Political Theories II	Political Parties and Interested Groups	Contemporary Political Systems
Introduction in the Law	Political Sociology	International Law	International Political Relations
Economics	Foundations of the Constitutional Law	Public Governance	Social Physiology
Foundations of the Political Science	Contemporary History and Macedonian History	Contemporary Economic Systems	International Organization and Integrations
Methodology for Political Science	Political System	Public Opinion and Mass Communication	Political Philosophy
Foreign Language I	Foreign Language II		
Defense and Protection			
Sports			

Table 1. Curricula for political studies 1993/94⁷

Since 2005 the political studies from the Law Faculty ``Justinianus Primus`` implemented the European Credit Transfer System. This system was introduced on European level in 1989 based on the principles from the Bologna Declaration. Until 2005 the duration of the political studies was four years studies or eight semesters. The implementation of the ECTS system meant a radical change in the duration of the studies (today they last three years and the master studies last two years). It also meant different curriculum, changes in the teaching methods and on the ways for checking the knowledge and the assessment. Particularly important are the changes that occurred with the ECTS system regarding the examination of the knowledge and the assessment and today they are consisted of electronic exams, essay writings and interactive teaching.

⁷ Curricula for political studies 1993/94, Development of the political studies curricula (1993-2005), ``Historical development-Law faculty Justinianus Primus 1962-2005, book II, Law Faculty Skopje, 2011:44.

I Semester	Politology	P o l i t i c a l Theories	Contemporary European and Macedonian History	F o r e i g n Language
II Semester	Constitutionalism	Law Theory	P o l i t i c a l Economy	Informatics
III Semester	Political System	Public Opinion and Mass Communications	Contemporary political Theories	P o l i t i c a l Sociology
IV Semester	Political Parties and Interest Groups	Contemporary Political Systems	P u b l i c Administration	Civil Society
V Semester	History of Diplomacy	International Law	Theories for piece and conflicts	S o c i a l Psychology
VI Semester	Contemporary Economic Theories	International Political Relations	P o l i t i c a l Philosophy Economic Policy	Local Government

Table 2. Curricula for political studies 2005/06

If we analyze the curricula from 2005/06 we can notice that there is difference in comparison with the curricula from 1993/94 in the number of the subjects and schedule of the subjects that are taught in each semester. The changes were made because of the adaptation of the curricula in the ECTS System and the new division of credits for each subject. If we see better we can notice that two subjects that were in the previous curricula from 1993/94 and those are Defense and Protection and the second one is Sports that were if we may say receditivs from same older times and system were fully ejected from the new curricula.

From the aspect of lectures regarding the political analytics and the need for developing the skills of writing, researching and collecting data on these studies are continually included experts from practice: political analysts, newspaper editors, etc. Also efforts are being made by the current head of the department for political studies to conclude agreements with the relevant institutions in order to engage students as volunteers.

2.1 Students

Over 25 years of existence on these studies more than 2770 students have been enrolled. It is interesting to mention that 50 students from the first year of their establishment graduated after four years of studies. Many former students from these studies today are renowned politicians and political analysts in the Republic of Macedonia. One of the founders of the political studies department is the current President of Republic of Macedonia prof. Gjorgi Ivanov.

The internal statistics show that some of the students that are enrolled at the political studies deal with political analytics while studying. At institutional level, efforts are being made engagement for students in foreign countries to be provided with international cooperation. The students with high grades have an opportunity to receive scholarships from the Ministry of Education and Science to continue the process of their education in foreign countries.

When asked to comment the job opportunities for the graduated students from political studies the dean of the political studies department prof. dr Zivko Andreevski from European Faculty in Skopje said: ``-And as a fact and as an encouragement I can say that list of jobs is quite large.

The graduated students can work as analysts of political processes specialized institutions, or they can establish agencies and institutes for themselves. In this manner, they can also organize public relations for political subjects, political parties and groups. There are also job opportunities in the state institutions, in the government services, in the ministries, departments and agencies, as well as in bodies of the judiciary, such as the Constitutional Court ``. He underlines that a large part of this graduated students could recognize their chance for work in the diplomacy within the Macedonian institutions in the country and abroad, such as embassies, consulates, but also as representatives in international regional organizations, external representative offices operating in the Republic of Macedonia and representations of international organizations of different types. This refers to the OSCE, NATO, the European Union, the United Nations, etc. A great sphere of job opportunities, adds Dean Andreevski, is open in the field of communications and media for example for analysts of the media system with opportunities to work as editors, journalists, image creators and on popularization for various institutions. Graduated students can find their opportunities in the commercial sphere and in the political areas from the state and the civil sector, but also from areas such as popularization of culture, education, health, and the like.

Although there are many job opportunities for the students from the political studies still it is evident that in the past years the interest for studying at these studies is decreasing. It can be seen from the picture below that in the academic year 2012/13 at the political studies department were enrolled 82 students. In the academic year 2013/14 the number of students enrolled was 73. It must be pointed out that at the same time another academic program at the political studies department was opened, here students have lecturers on English language. At 2013/14 academic year 14 students were enrolled on this program. From the picture below can be seen that there is decreasing interest for the political studies in the academic year 2014/15 when 51 students were enrolled on the political studies on Macedonian language and 6 students on the English language program. Unfortunately the same trend can be seen in the other academic years: 2015/16 (38 students were enrolled on Macedonian language program and 12 students on English language program); 2016/17 (39 students were enrolled on Macedonian language program and 13 students on English language program); and 2017/18 (41 students were enrolled on Macedonian language program and 7 students on English language program);



2.3. Postgraduate studies

The Faculty of Law also organizes postgraduate and doctoral studies in the field of the political science. In 2017 for the first time joined degree in Doctoral studies in fields of Communology and Political Sciences was organized.

In 2005, the ECTS criteria applied in the postgraduate studies. Today there are two modules of postgraduate studies: International relations, European integrations and diplomacy and Public policies and political system.

In their 25 years period of existence numerous students were enrolled on the postgraduate studies at the department for political studies at the Law Faculty 'Justinianus Primus'. The number of students that obtained master degree is decreasing in the past years followed up by the decreased number of students enrolled at the undergraduate political studies. The same is with the number of students that obtained PhD diploma in the field of political science.

3. Periodization of the political science in the Republic of Macedonia according to the methodology of the scientific papers

In the effort to establish the path of the institutionalization of the political science in the Republic of Macedonia two methods can be used. One is comparison of the curricula over the years and the other is with analyses of the papers written by the academic staff and scientist engaged in the field of the political science.

Namely, the methodology used in the research is very important and is also defined by the nature of the subject of the research. Thus, for example, the possibility of quantitative research (measurements, experiment, calculations) is much greater in the natural sciences, hence the high degree of reliability and different valuation of the knowledge of the natural sciences. Regarding the social sciences today, we may say that there is empirical orientation and that is confirmed by the increasing number of quantitative research and with the more frequent consulting of the scientific results in practice.

It is emphasized that the empiricism also shows the development of the social sciences. For the development of social sciences in the 20th century⁸, two interconnected

⁸ The Social science has developed its own methodology, especially in the last 200 years, when it is possible to talk about the science of the society, and not for philosophy. In this direction, with the development of the empirical techniques in the United States (in the 50s and 60s of the 20th century), the pursuit of excellence is more pronounced, which also affects the strategic orientation in science.

tendencies are characteristic: the increasing role of the empirical orientation, which leads to an increase in the number of quantitative and topical research and a growing specialization, which is expressed to the stratification of science and the separation in sub-disciplines^{9 10}. The development of the sophisticated methods of research and checking enable the elimination of subjectivism in the attitudes of the society and enable them to turn from one intellectual-philosophical conception of social trends into scientific and quality knowledge that can be checked. The sophistication of the methods and their adaptability to particular subject determines the quality of the science so in that manner we may say that the more expensive the methodology is the more successful the science will be.

It should be noted that the position of the science in countries is directly correlated with their economic development. A series of empirical indicators confirm this correlation, for example: the number of researchers is rapidly increasing, the amount of money planned for funding scientific activities, the number of scientific institutions, etc. The largest number of researchers per capita has Japan. In the last decade of this century, the percentage of income allocation for scientific and research work from the gross national product ranges from 3% of GDP in developed countries and less than 1% in underdeveloped countries.

If as a criteria for the success of the science in one country is the amount of budget funds that is invested in its development then there is need for short comment on the facts in Macedonia. Namely, the amount of money devoted on science and research¹¹ in Macedonia in 2018 was for 30 percent lower than it was in 2017. Slovenia is the leader in the region with 2.2 percent of the gross domestic product devoted on science and research. Republic of Macedonia set a modest 0.2 percent. Serbia, Croatia and Bulgaria stand at between 0.7 and 0.8 percent of the gross domestic product devoted on science and research.

⁹ Antonija Kloskovska, Sociologija kulture, Cigoja stampa, Beograd 2001, pp. 7

¹⁰ Antonija Kloskovska, Sociologija kulture, Cigoja stampa, Beograd 2001, pp. 7

¹¹ http://www.fakulteti.mk/news/17-11-23/reakcija_na_profesori_budzhetot_za_nauka_za_2018_e_poguben_za_mladite_nauchnici.aspx, visited on 05.04.2018.

When asked to answer how the Macedonian science will survive this situation prof. Dimitrov, former dean of the Technological Faculty in Skopje answer: `` Scientists face big problems when there is not enough money. This decision will be detrimental to young scientists who have yet to build a career. To apply for a major project abroad, to offer some great research, you need a good background. All funds applications require each scientist to offer what he has done in the past. What will the youth offer when there is no money for research at home?¹².

If we take the methodology used in research in the academic papers from the field of the political science as a criteria for periodization of the development of political science in the Republic of Macedonia, we can generally distinguish three periods of development of the political science in the Republic of Macedonia.

1. The first period is the beginning of the 90's when in the academic papers from this field we can find argumentations for the concepts of democracy and division of power.
2. The second period begins with the emergence of the Internet and the increasing mobility of the academic staff (scientists, professors, students in the west). We can say that this period is defined with empirical tendency in the political science.
3. The third period is a period when the socio-economic level of the development and globalization initiates the need for exact and applicative knowledge of the social economic and political trends, psycho-social phenomena, for which there is awareness in the scientific field, but we do not have enough investment, conditions and competitiveness for that. As a result of this development, today we have the most creative phase of scientific engineering, which means putting emphasis on the experiential data, possibilities for checking the hypothesis, usage of statistical surveys, measurements, experiments, surveys, etc.
4. Interview with the Head of the Department of the political science prof. Nenad Markovik, PhD.

¹² Ibid.

Professor Nenad Markovic is Associate professor at the political studies department at the Law Faculty in Skopje ``Iustinianus Primus``.

1. How will you comment the development of political science in comparison with the development of the curricula?

I think that the development of political science in the Republic of Macedonia is rather modest. The first reason for this is that the number of scientists working in the field is very small. This means that they can not work on the many research fields that there are in the political science. The second, is the quality of the academic staff. I consider that there is a huge space for improvement, not so much in the field of normative politics, as in relation with the methodology of political science, where the existing of the academic staff is more than modest. The third reason is not having a separate Faculty of Political Science that would serve as a focal point around which all the political scientists would gravitate. Finally, many disciplines of political science (security, international relations, etc.) are located at other faculties and scientific institutions and not in one academic point in which they would develop. On the other side, I think that the curriculum was always at the dissent level. However, the last change introduced several years ago, stemming from the Higher Education Law, formatted too big and too much heterogeneous curriculum, which I think is almost dysfunctional. I find also that the curriculum lack from methodology and applied political science and on the other hand there is there is too much theory.

2. According to your opinion what kind of impact does the political science have in the Macedonian society?

Unfortunately not too big. If the direct participation of certain political scientists in various jurisdictions is taken away, science is ignored "by necessity". Also, "by need" is used when it is politically correct. At the level of the scientists working at the field, the impact should be much more influential.

3. According to your opinion what is more common in the political science in the Republic of Macedonia the research or the theory? Do you have the knowledge who finances the research in the political science in Macedonia?

There is a research in the political science but I must say that is on behalf on the individual efforts of certain political scientists. There is no systemic investment in scientific funds by the Universities or the Government. And if there is research , the funds are too modest to carry out serious and comprehensive research. Funds can still be found through the FP7 or H2020 program of the European Commission, the German foundations, the Swiss funds through the SCD or the RRPP program, the US funds through US AID, etc.

4. According your opinion where was the political science at the beginning of the 90`s, and where is today?

Today, the political science in the Republic of Macedonia is far more development. At the beginning of the 90`s the political science was in the nascent and part of the legal science. Today, the political science is a separate science with a certain weight. There are also more political scientists who are devoted exclusively to the political science. This certainly improves the position of the political science. In relation with the research today more articles are published from the field of political science but still there are many things to be improved.

5. According to you, why the interest among young people for political science is declining?

According to me there is not downplay of the interest. The number of young people decreases as a consequence of depopulation and the spread of competition among higher education institutions. However, there may be a slight decrease in the number of students because it is very difficult to find a job after graduating on political science. But this is a problem with all social sciences not just with the political science.

Conclusion

The foundation of the political science in the Republic of Macedonia was established in the beginning of the 1990`s as a necessity of the transition process and the urgent need for improved understanding of certain social events. This urgency was reflected in the theoretical frame of certain social and political phenomena and their empirical monitoring. The main topics that become dominant on the classes were the basic ethical, political and economic pillars on which capitalism and Western democracy relies. At the

same time dramatically rejection of certain theories that were previously dominant over the years happened and this can be seen after the analysis of the curricula of these studies. After the establishment the political science was continuously developed. That is why when making analyze of the methodology used in the academic papers we can distinguish three periods of development of the political science in the Republic of Macedonia. Unfortunately the main characteristic of the development of the political science is lack of funds for research and science devoted from the University and the Government. Still and despite that fact as we saw in the interview with prof. Markovic there are enthusiastic scientists that manage to find funds from foreign supporters and manage to maintain the evolution of the science on satisfactory level. The situation cannot be left on this level. If we want to establish qualitative political science final support from the Government is inevitable. The recommendations from this research are in that direction: The Government to find way to finance the research in the field of political science so that the political science can become competitive and can follow the development of worlds' political sciences.

Mrs. Milena Apostolovska-Stepanoska, *PhD is Assistant Professor at the Law Faculty "Iustinianus Primus" Skopje. She teaches Sociology of Law at the Law Department, Political Sociology at the Political Studies Department and European Integrations at the Department for Journalism. In 2015 Apostolovska-Stepanoska defended her PhD thesis titled "The European Institutions and the European Identity".*

Her main field of academic interest and research is the European Union and more specific the European Institutions. Apostolovska-Stepanoska had participated at numerous international conferences and meetings where she presented her work. In the past year she presented the paper titled "The European Citizenship and the European Identity" at the 4th International Scientific Conference Social Change in the Global World that was held in Shkup on 6-7 September 2017; the International Conference "Rethinking the European Union" in Sofia, Bulgaria, 11-13 May 2017. Apostolovska-Stepanoska had presentation of the paper titled "The Rise of Populism and Euroscepticism" (paper with co-author). At the International Conference in Sofia Bulgaria held at 26.10.2017. Apostolovska-Stepanoska presented the paper: "The European Citizens' Initiative: A Step Forward or Not in Reducing the Democratic Deficit in the EU", etc.

ARAB-WEST INTERNATIONAL RELATIONS: JÜRGEN HABERMAS TO BALANCE FUTURE WESTERN FOREIGN POLICIES TOWARDS THE MENA REGION

MOHAMMAD AHMAD HASAN AL-JARARWAH

A current Ph.D. Candidate at the University of Newcastle, Australia, and Defence Analyst & Translator, Canberra, Australia

ABSTRACT

Throughout history, many political observers in the Arab-Islamic and Western worlds have held prospects for cooperative and benevolent socio-political and cultural relations between the respective regions. In the fields of Western public diplomacy and foreign policy, there exists a considerable amount of academic research that has been conducted in order to enhance Arab-West inter-governmental and inter-ambassadorial relations. In spite of this, political observers have subsequently become discouraged by the tenuous outcomes of Arab-West international dialogues, especially when reflecting upon the devastating situation currently facing Arab nations in the Middle East and North Africa (MENA) region. Therefore, it has become pivotal to transition the old-fashioned Western foreign policies into more accommodating policies, predominantly since the approaches of Western international relations theory (IRT) have been designated as Eurocentric, prejudiced and inadequate. In addition, this theory is claimed to be derived from the philosophical foundations of international relations, where the ontological foundations have received little attention. Considering this, the paper proposes that Jürgen Habermas's critical theory and the theory of communicative action; present rational and urgent notions for Western inter-governmental and inter-ambassadorial relations with Arab nations, provide contemporary ramifications for future Western diplomacy and foreign policies and offer opportunities to inform Western representatives about the vital and constructive Habermasian intuitions in order to guide Western inter-governmental and inter-ambassadorial relations towards the MENA region. The findings exposed blind spots and various biases that invariably

sit at the heart of Western foreign policies towards the MENA region, and revealed vigorous elucidations that safeguard Arab-West international relations. Finally, the paper concentrates on applying rational Habermasian epistemologies in order to constructively contribute towards the desired strengthened Arab-West international relations and to bridge the gap of existing apprehensions.

Search Terms: Western public diplomacy, Western foreign policies, Arab-West international relations, MENA region and Jürgen Habermas

THE FIRST PART OF AN INVESTIGATION OF GREEK STUDENTS' USE OF STUDY SKILLS WITHIN THE LEARNING CONTEXT OF AN ENGLISH FOR SPECIFIC ACADEMIC PURPOSES COURSE

OURANIA KATSARA

University of Patras, Department of Business Administration of Food and Agricultural Enterprises

ABSTRACT

The role of study skills in learning has well been discussed in the literature but there is little research regarding Greek students' use of study skills within the context of an English for Specific Academic Purposes (ESAP) course. This paper discusses the first part of a survey on Greek students' use of study skills by using the categorization of effective studying which refers to study skills, study habits and study attitudes outlined by Crede and Kuncel (2008). An analysis of 72 self-assessment questionnaires completed by first year students of the Department of Administration of Food and Agricultural Enterprises in University of Patras indicated that most Greek students were not confident employing study skills while they rarely engaged in intentional study behaviour. Specifically, it was identified that students rarely made use of their metacognitive knowledge on specific task and strategy variables and rarely made use of their metacognitive skill of evaluation. The main finding of the survey highlights the importance of initiating the learning process by indicating that Greeks' choice of tasks during their study seem to be linked to self-efficiency beliefs and interest in the task. A set of preliminary implications, which could be used to establish the parameters for further research are also offered.

Keywords: study skills, study habits, study attitudes, Greek students, English for Specific Academic Purposes

1. Introduction

Learning can be seen in terms of three elements: intention, process and outcome (Marton, 1976). In light of this view, Allan and Clarke (2007, p. 65) argue that effective support of learning focuses on three facets: a) the type of skill-oriented outcomes which students are expected to learn, b) the type of learning activities which are most likely to result in these desired outcomes and c) the curriculum design structures at a program level which offer the most effective environments. Entwistle and McCune (2009) maintain that a key issue in academic understanding within learning contexts has been linked to students' determination to use knowledge in new contexts as well as showing alertness to possibilities for applying them. Therefore, as Entwistle (2007) argues in this sense, the main implication indicates the need for suggestions on what approaches are most likely to contribute to powerful teaching-learning processes.

A key issue is the conceptualization of the notion of need. Eslami (2010) argues that the literature indicates the complexity of language needs. Specifically, there is a distinction between the necessities of demands and learners' wants and the methods of bridging the gap between these two while there is a need to go beyond the descriptive approach of needs analysis by considering critical needs analysis (Benesch, 1996; Brindley, 1989). Benesch (1996) maintains that critical analysis acknowledges existing demands but considers target situation demands as a site of possible reform. It is assumed that institutions and hierarchical and people at the bottom should be truly empowered since the need needs to be considered in terms of the unique characteristics of the educational context in which the study takes place (Holmes & Celani, 2006).

The Greek case is an interesting one since the university law affects Greek students' attitudes towards English for General and Specific Academic Purposes (EGAP, ESAP) courses. Katsara (2016) noted that according to university law, attendance of lectures is not compulsory and every department's assembly decides on the number of courses offered in their curriculum. More importantly, opinions of a course are formed as a result of an agreement among teaching staff in each department and there are cases where exemptions from attending the course are permissible for students who are holders of certificates of general use. In a study carried out by Katsara (2008a) Greek students reported that there is a need for Academic teaching staff at Greek universities to be informed of the difference in teaching methodology between general

English as a foreign language (EFL) courses and EGAP and ESAP courses. Katsara (ibid) suggested that the EGAP/ESAP teacher has a crucial role to play ensuring that students are offered appropriate teaching tailored to their needs by cooperating with the other teaching staff of each department. This implies that needs analysis having as a purpose the design of a useful language course is necessary.

This article discusses the first part of a survey undertaken at the University of Patras in the Department of Business Administration of Food and Agricultural Enterprises regarding students' self-assessment of their learning behavior with regard to study skills use. Having students self-evaluate their use of study skills could help in gathering data regarding students' commitment to use study skills and an opportunity for teachers to understand students' learning. According to Kierkegaard "true instruction begins when instructors understand their students and their attitudes to learning" (as cited in Felder & Brent, 2005, p.69). Felder and Brent (2005) furthermore argue that an important component of that understanding is awareness of the different attitudes students have towards learning, the different ways they approach it and how teachers can influence both their attitudes and approaches.

The research questions that informed this study are the following: a) how does self-assessment help in identifying Greek students' knowledge on study skills? b) how does self-assessment help examine the nature and importance of study skills worrying such students?

2. Literature review

In order to contextualise the main argument of the study, this section offers a critical literature review on the framework of studying patterns during learning and specifically in Greek students' studying at university.

2.1 Study skills, study habits and study attitudes

Study skills have been discussed in various ways in the literature. Researchers seem to agree that study skills refer to appropriate behaviours in order to accomplish a learning task functioning as a process and being critical tools for learning (Gall, Jacobsen & Bullock 1990; Rafoth & DeFabo 1990; Yu, 2011). Crede and Kuncel (2008) argue that study skills refer to students' knowledge of appropriate strategies and methods and the ability to manage time and other resources in order

to meet the demands of academic tasks and therefore, effective studying refers to study skills, study habits and study attitudes. It is important to note that in a literature review Gettinger and Seibert (2002) maintained that study skills are essential to academic competence since effective study skills are associated with positive outcomes across multiple academic content areas for diverse learners.

Firstly, study skills refer to students' possession of knowledge of appropriate studying techniques and the ability to manage time and other resources to meet demands of academic tasks. A key concept is metacognition. It is generally accepted that metacognition acts as meta-level and is related to the object-world (i.e. cognition) through the monitoring and control functions (Nelson, 1996). Thus, metacognition has a dual role: a) it forms representation of cognition based on monitoring processes and b) exerts control on cognition based on the representation of cognition (Flavell, 1987). Flavell (1979) argues that the basic manifestation of the monitoring function is metacognitive knowledge while on the other hand, metacognitive skills or use of strategies is manifestations of the control function (Brown, 1978).

Metacognitive knowledge refers to acquired knowledge about cognitive processes of one's own cognitive skills. Flavell (1979) further divides metacognitive knowledge into three categories: knowledge of person variables, task variables and strategy variables. Knowledge of person variables refers to general knowledge about how humans learn and process information as well as individual knowledge of one's own learning processes. For instance, someone might know that he/she will be more productive if he/she works in a quiet place where there are no distractions. Knowledge of task variables includes knowledge about the nature of the task as well as the processing demands needed for each individual. For example, someone might know that it will take more to comprehend an extract than it would for someone to read and comprehend a novel. Finally, knowledge about strategy variables include knowledge about both cognitive and metacognitive strategies as well as knowledge on when and where it is appropriate to use such strategies.

Metacognitive skills refer to the ability to use metacognitive knowledge strategically in order to control cognitive activities and to ensure that cognitive goals (e.g. understanding a text) are met (Desoete, 2008). In other words, metacognitive skills refer to procedural knowledge referred to as 'executive processes' within appropriate time allocation (Brown, 1978). 'Executive processes' skills are discussed in the literature and comprise four activities, namely: a) prediction, b)

planning, c) monitoring, and d) evaluation (Desoete & Roeyers, 2002). Prediction skills enable students to predict the difficulty of a task by selecting appropriate strategies and allocation of resources, in other words they involve orientation of task requirements. Planning refers to steps to be taken for task processing. Monitoring refers to one's awareness of comprehension and task performance, for example engaging in periodic self-questioning while reading a text in order to understand the material (Winnie, 1997). Finally, evaluation skills enable students to evaluate their performance on the task, for example by comparing their performances with each other and by using this comparison in order to locate the error in the solution process (Lucangeli, Cornoldi, & Tellarini, 1998)

Secondly, study habits denote the degree to which students self-regulate, their ability to concentrate and engage in regular acts of studying characterized by appropriate studying routines (e.g. reviews of materials, self-testing, rehearsal of learned material etc.) occurring in an environment that is conducive to studying (Crede and Kuncel, 2008) Thirdly, study attitudes refer to students' positive attitude towards specific acts of studying and sense of responsibility for the value in one own's learning by indicating study motivation when making sustained and deliberate effort (ibid). In other words, study habits and study attitudes are multidimensional in nature, since deliberate effort (study motivation), self-regulation, ability to concentrate, self-monitoring (study habits) and sense of responsibility in one's own learning (study attitudes) are needed in order to be successful academically.

It is important to note that interest and will are very important for study habits and attitudes since individual differences can be analysed in terms of control focus and gender. According to Bacanlı (2002, p. 133, as cited in Ozoy, Memis & Temur, 2009, p.156) when study habits are analysed in terms of control focus, students who have inner control do not need to be controlled when they undertake assignments. However, students who are controlled with outer factors often need guidance and encouragement. Houtte (2004) additionally argue that when the differences are analysed in terms of gender, female students are more successful academically than male students having better study habits and attitudes.

2.2 The role of teachers in developing students' study skills

Gettinger and Seibert (2002) argue that the social-cognitive perspective of self-regulation and academic competence is useful in designing effective study-strategy instruction. Specifically, academic performance develops initially from social sources- teachers and peers and eventually

shifts into internal sources- self (Schunk & Zimmerman 1994 as cited in Gettinger and Seibert, 2002, p. 359). In the Greek context, Karagianpoulou (2007) argues that research in higher education seems to focus on issues linked to university entrance examinations, effect of social inequalities on students' access to university, money invested in State universities and family money paid to pre-university exam preparation centres (phrondistiria). However, as Karagianpoulou (2007) argues few studies examine learning and teaching from the Greek students' perspective being beyond the scope in many cases of any macro-level analysis. Oleson and Hora (2014) argue that the majority of Greek academics have not received any formal training on teaching probably indicating that academics develop teaching patterns mostly through experience and reflection. This is consistent with findings from a survey conducted by Kedraka and Rotidi (2017), who argue that Greek academics seem to focus more on the domains of knowledge Curricular (aims of teaching) and Pedagogical (knowledge about teaching and learning processes) than in Instructional (teaching practices).

Stronge, Ward and Grant (2011) argue that instructional delivery includes a variety of teachers' responsibilities connecting the curriculum and the student. Specifically, they argue that instructional delivery can be discussed under the following areas: instructional differentiation, focus on learning, instructional clarity, instructional complexity, expectations for student learning, the use of technology, and the use of questioning. Instructional delivery that focuses on learning is an area that highlights the importance of study skills. According to Zahorick et al. (2003) effective teachers consider students as the central reason for educational institutions to exist-learning arguing that effective teachers are the ones who focus on providing students with basic academic study skills and critical thinking skills.

2.3 Research on Greek students' use of study skills

There is not much published research into Greek students' use of study skills at university. A study by Georgada, Kanthilorou and Livatha as cited in Lakasa (2008, para 6) showed that students from University of Athens and University of Macedonia lack study skills. It was found that Greeks are in favour of rote learning without understanding what they study, not being able to keep notes while from the ones who do keep notes, one in two does not know how to deal with them and therefore few look at them before exams.

A study by Chostelidou (2010) underlined the importance of academic study skills. In her survey, it was found that teaching arrangements in the Department of Accountancy in the A.T.E.I of

Thessaloniki, Greece were not at all in agreement with the identified needs of the Greek students. Students appeared to have different expectations in relation to their need to use English for study and/or professional purposes. Chostelidou (2010) suggested that an approach to English for specific academic purposes (ESAP) courses should integrate academic skills with subject specific skills deriving directly from the subject discipline (Jordan, 1997) because it could facilitate learners in the learning process as well as motivate them to become involved in the ESAP course.

Katsara (2010) conducted research in relation to students' needs when studying for an ESAP course at university and it was found that Greek students' concerns were related to misunderstandings of study methods. In this survey students noted that getting information from the teacher could be the best support strategy to help them adjust to the new academic environment. However, research findings indicate that Greek private in contrast with teachers working in state institutions show a great interest in their students being flexible to adapt teaching to the students' needs (Polychronaki, 2004). This shows that needs assessment in the public education sector should be considered as an on-going process designed to gather and analyse information about the learners' needs in an existing setting or to plan learners' and program's future directions and making informed decisions (Pupura & King, 2003).

Based on findings and suggestions made by Georgada, Kanthilorou and Livatha (2008), Chostelidou (2010), Katsara (2010) and Polychronaki (2004), it is important to carry out research on the use of Greek students' self-assessment responses as a basis for changing learner activities in the syllabus or adopting different teaching approaches, corresponding to students' needs especially if instructional goals for tasks are part of learning activities (Geeslin, 2003). Katsara (2014) responded to this by conducting a survey where it was found that Greek students proved willing to self-assess their exam taking techniques recognizing that are not properly trained to deal with exam papers for an ESAP course. Students' answers were not consistent since some of them (38.23%) reported that they were not confident to employ certain strategies. Katsara argued that this finding indicated that Greeks need specific instruction on how to apply exam taking techniques since as Langer (2002) contends the way in which students perceive assessment will determine the way they respond to it.

Research Method

Purpose of the study

The present study is concerned with the identification and recording of the Greek students' use of studying behaviour during their studies. The motivation for the study as indicated in the literature review stems from: a) the fact that knowledge about students' studying behaviour should help in designing appropriate teaching methodologies contributing thus to students' reflection of the learning process and to their academic development, b) the absence of empirical research about the topic in Greek universities. The ultimate aim of the study is to collect data about students' studying behaviour and based on these data design extra learning activities, which could help students study effectively.

Research setting: Overview of the ESAP course and learning approach

In the Department of Business Administration of Food and Agricultural Enterprises, two ESAP courses are offered being compulsory subjects in the departmental curriculum for the first two semesters and the grades obtained count when calculating the final degree. The department's curriculum offers only three hours of teaching per week and therefore the teacher has to select appropriate teaching materials to be included in a short syllabus. Based on this limitation, the teacher decided to design a teaching approach and a syllabus based on the argument put forward by Hutchinson and Waters (2002, p. 19), who argue that ESAP must be seen as an approach and not as a product since this approach to language learning is based on learner needs. This implies that studying behavior is an important indicator in employing appropriate teaching strategies. Katsara (2008b) found that Greeks appeared to be intimidated by the teacher's comments in an ESAP class. The researcher suggested that the ESAP teacher in a Greek context should be as encouraging as possible in order to create a supportive atmosphere. Specifically, Katsara suggested that teachers should foster group cohesion by instructing students on the true meaning of unequal contribution in the group. Based on the study's results Greeks appeared to realize the importance of the task in relation to student goals within the group. This is suggested to strengthen the bonds between high achievers and weaker ones since group productivity reached a peak when co-workers felt accepted. The teaching approach therefore dictates that the

teacher acts as a facilitator by moving around from table to table to help each group of students complete the weekly task.

The syllabus of the course is as follows. In the first term, the focus is on students' understanding of the basic skills in the business domain where constant opportunities for reading, writing, listening and speaking activities are given to students (company memo, press releases, corporate blog, writing a business report, presenting reports and graphs, debating). In the second term, emphasis is placed upon students' further professional and academic needs. The teaching sessions include basic terminology in Agribusiness and Agriculture domain, training on advanced reading skills, guidance on improving coherence, cohesion, unity in an academic text, advanced oral presentation skills and listening practice in the field.

Every class is divided into two parts. During the first part, the teacher teaches and explains a skill, for example how to read and understand a business text. Exercises from the course- book are used to explain the skill. For example, students are asked to read a text with an underlined word and answer a multiple-choice question with definitions of the word. A second task is often one that requires students to answer another related question where the object is to provide evidence from the text that supports the chosen definition. Then additional exercises are distributed to groups of students in order to help them practice this skill. For example, vocabulary exercises where students are asked to write the correct word(s) to complete texts are done. Students are asked to read the whole text and try to understand what the text is about. In some exercises words are given in a box and sometimes there are more words than gaps, therefore students are advised to start with the words they know. For the unknown words students are asked to guess their meaning by a) examining the immediate context of the word (e.g. read the whole sentence before and after the gap and try to identify what type of word is missing, (i.e. noun, verb, preposition, pronouns, articles etc.); b) examining the wider context of the words (i.e. other sentences in the paragraph); and c) checking the structure of the word (i.e. prefix, suffix, root).

Participants

Seventy-two (72) first year students from the Department of Business Administration of Food and Agricultural Enterprises completed the self-assessment questionnaires. 63.88 % of them were male and 36.11% of them were female.

Instrument

First year students were asked to complete a self-assessment questionnaire on how often they use study skills when they study. Questions 1-4 contained information regarding gender, department of study and students' overall feelings in relation to their confidence in employing study skills. Questions 5-34 in the questionnaire were adapted from the University of Central Florida's Student Academic Resource Center. These questions were used to measure Greek students' frequency of making use of study skills while studying asking them to rate frequency using the Likert scale rarely, sometimes and often. Questions 5-9 contained items in relation to reading skills. Questions 10-14 contained items in relation to note taking. Questions 15-19 contained items in relation to study habits. Questions 20-24 contained items in relation to memorizing techniques. Questions 25-29 contained items in relation to preparation for tests techniques. Questions 30-34 contained items in relation to time management.

Data analysis

Data collection

Sampling for the selection of students completing the self-assessment questionnaire was based on the notion of random purposeful sampling. According to (Sandelowski, 2000), this strategy is employed when there is a very large pool of potentially rich-cases. In the current study, the purpose of the entire research was to make use of a self-assessment tool for students attending classes in order to design activities, which could help in improving the teaching procedures for Greek students. Thus, one would learn a lot from gathering information from a large sample of the whole population of students registered for the course rather than from focusing on understanding the needs of a small number selected students.

On the first day of the winter term, after the initial presentation of the course to be taught, the tutor invited the 72 out of the total 160 first year students enrolled in the department attending the initial session to fill in the self-assessment questionnaire in relation to their use of study skills when studying English. Ethical issues were discussed and students were informed about ethical matters regarding confidentiality and anonymity. They were informed that the main aim of the analysis of these questionnaires was to identify students' weaknesses in order to design activities that could help them improve their study skills

Data analysis

This first part of the survey discussed in the current article uses quantitative data in order to identify parameters that need to be researched further in a future qualitative study. Johnson & Onwuegbuzie, (2004) argue that mixing research aims at expanding one's understanding since it helps in legitimizing the use of multiple approaches in giving answers to research questions rather than restricting researchers' choices. According to the researchers (ibid) an advantage of the mixed research method is that if findings are consistent across a variety of approaches then greater confidence in reaching a singular conclusion is enhanced. On the other hand, if findings conflict then the researcher can modify certain interpretations and conclusions accordingly.

Presentation and discussion of results from the self-assessment questionnaire

Students' full report on how often they employ study skills is offered in appendix A. Students' responses indicated that the majority of them (73.61%) were not confident employing study skills during their learning. Looking closely at the results as shown in tables 1,2 ,3, it is indicated that students made use of certain study skills whereas specific study habits and study attitudes were discernible.

Table 1.

Study skills, study attitudes, study habits	Rarely %
I make questions from a chapter before, during and after reading	44.44
I compare my notes with a classmate	44.44
I rework, rewrite or type up my notes	39.75
I study at least two hours every hour I am in class each week	34.72
I study with a classmate or group preparing for tests	33.33
I start papers and projects as soon as they are assigned	13.88

Table 2.

Study skills, attitudes, study habits	Sometimes %
I take notes as I read my text books	74.41
I look for familiar concepts as well as ideas that spark my interest as I read	56.94
I start papers and projects as soon as they are assigned	55.55
I have enough time for school and fun	55.55
I quiz myself over material that could appear on future exams and quizzes	52.77
I set study goals, such as the number of problems I will do or pages I will read.	40.27

Table 3.

Study skills: Metacognitive Knowledge

Students' responses showed valuable insights about their metacognitive knowledge. Aspects of all three types of metacognitive knowledge were identified.

Knowledge of task variable

It was shown that students did not seem to be fully able to process the demands needed about the nature of the academic task they engaged in. Results indicated that students seem to be unaware of how to keep and work on notes in order to understand and apply the material. Ward and Tatsukawa (2003) argue that two are the main functions of note-taking. Firstly, notes are useful when reviewing and secondly the process of note-taking itself helps students learn the material. This is explained in terms of encoding. In the process of taking notes, students have to re-express the inputs received when reviewing the material and while doing so, it is claimed that the ideas get re-encoded mentally in an easier form for them to apply and remember. The results of the current survey show that even though 74.41% of the Greek students sometimes take notes as they read text books, and 47.22% of them often try to organize main ideas into a meaningful method, 39.75% of them rarely rework, rewrite or type up those notes.

Knowledge of person variables

Results indicated that students seem to be fully able to control their individual knowledge of their own learning process. It was found that 54.16% of them often try to study during my personal peak energy time to increase their concentration level. This finding shows that students appear to engage in memorizing techniques since as Entwistle and Entwistle (2003) argue “memorization” is a largely mechanical process of forcing knowledge into memory by conscious effort (Au & Entwistle, 2001, as cited in Entwistle and Entwistle, 2003, p. 36).

Knowledge about strategy variables

Students’ responses revealed that they did not seem to acquire full knowledge about strategy variables which includes knowledge of both cognitive and metacognitive strategies and knowledge on when to use them. Results indicated that 58.33% of the students use metacognitive knowledge in order to fill in any gaps in their knowledge since they often try to develop a strategy

to solve the problem by trying to guess the meaning of new words as they see them for the first time. This finding implies that students possibly made use of “anaphoric inferences skills” perhaps by cross referencing between synonyms and their referents in the text (Cromley & Azevedo, 2007). However, their study skills use relating to particular content such as reading for meaning indicates that students were not confident. Greeks appear not to use their metacognitive knowledge strategically in order to understand what they read in full. Even though 56.94% of them sometimes look for familiar concepts as well as ideas that spark their interest as they read, 44.44% of them rarely make questions from a chapter, before, during and after reading. This finding shows that Greek students appear to be surface readers since they try to understand meaning of actual words and phrases (Van Dijk & Kintsch, 1983) and not deep readers who according to Bowden & Marton (2000, p. 49) make connections to already known concepts and use this understanding for problem solving in new contexts. As Tobias and Everson (1996) argue if students cannot distinguish between what they know and do not know, they can hardly be expected to exercise control over their learning activities or to select appropriate strategies to attain their goals. This finding implies that students’ “gap-filling inferences” and “Knowledge-based inferences” are weak. Graesser et al. (1994) argue that “gap-filling inferences” make use of information from outside the text, from the reader’s existing knowledge. “Knowledge-based inferences” are reading skills stored in the long-term memory (e.g. earlier sections of the current text which has already been encoded in the long-term memory) that becomes activated in the meaning representation of the current text. In the current survey, Greeks reported that they rarely make questions from a chapter before, during and after reading. Therefore, they seem not to rely on the activation of the “mediating idea-missing idea” from their knowledge without which the text is disjointed (Bowyer-Crane & Snowling, 2005).

Study skills: Metacognitive skills

Predicting, Planning, Time allocation

Findings showed that students do not seem to manage their time properly. Research in the literature indicates that deficiency of skills in terms of effective time management is often one of

the most important problems in academic learning (Glenn, 2003) and that the first step of effective time management is making a plan and conforming to it (Ulug, 2000, as cited in Özsoy, Memiş, & Ve Temur, 2009, p. 157). The results of the current survey seem to confirm this. A paradox in their reports revealed that even though Greeks rarely start papers and projects as soon as they are assigned (13.88%), 48.61% of them often appear to report that they do all homework assignments and turn them in on time. However, looking at their responses carefully, this paradox could explain the fact that some (55.55%) sometimes have enough time for school and fun. This finding might mean that students do not always seem to predict the difficulty of a task in order to organize their time between academic and non-academic activities. It is important to note that students' responses on time allocation might reflect cultural characteristics in relation to time orientation indicating that Greece is a time affluent society. Hirschon (2013) argues that based on earlier work by Linder (1970) time affluent societies, for example Greece have a weak ability for forward planning and events are arranged at the last minute where action and programmes are frequently disrupted.

Monitoring

It was found that 52.77% of the students sometimes quiz themselves over material that could appear on future exams and quizzes. This indicates that Greeks are not fully committed to memory even though they engage in memorization techniques (see knowledge of personal variables above). Ausubel, Novak, & Hanesian, 1978 (as cited in Entwistle and Entwistle 2003, p. 36) argue that “committing to memory” is more like “meaningful reception learning” repeated several times (Ausubel, Novak, & Hanesian, 1978, as cited in Entwistle & Entwistle 2003, p. 36).

Evaluation

Greek students' responses showed that they might not prepare properly for examinations. Entwistle and Entwistle (2003) maintain that preparation for exams cannot be seen wholly in isolation from more general aspects of studying. It is argued that what students do when they

begin their final preparation for exams is dependent on what they have done previously. It was found that 39.75% of them rarely rework the notes they keep implying that their understanding of the material might be weak while 44.44 % of them rarely compare those notes with a classmate, which shows that students' metacognitive skill of evaluation is weak. Lack of comparison between notes in order to locate possible mismatches, which could help students understand the material better might also explain the fact that 33.33% of the students rarely study with a classmate or group to prepare for exams. These findings corroborate with Katsara's (2008b) results where Greeks reported that they felt that in group work there is unequal contribution among its members.

Study habits and attitudes

In general terms, 55.55% of the students reported that they often study where it is quiet and has few distractions. This finding reflects students' ability to concentrate in an environment that is conducive to studying. Students appeared to prepare for study as they reported that they organize the place of study in such a way that it facilitates them in terms of environment adopting an atmosphere that is suitable to read both physically and psychologically in terms of person. This reflects Baltas' (1998, as cited in Demir, Kilink & Dogan, 2012, p. 427) argument in relation to organizing studying environment. Additionally, students' responses showed valuable insights about their study behavior. Aspects of their motivation, self-regulation and sense of responsibility were identified.

Motivation, Self-regulation and Sense of responsibility

Results indicated that students appear not to show any consistent intentional study behaviour. According to Zimmerman, Bonner & Kovach (1996) study skills involves a self-regulatory dimension since for example initiative, persistence and goal setting is important in studying for both the initial development of study skills and the application of skills outside of formal learning contexts. In the current survey, it was found that 47.22 % of the students often use a "to do" list

to keep track of completing their academic and personal activities and 40.27% of them sometimes set study goals, such as the number of problems they will do or pages they will read. However, 34.72% of them rarely study at least two hours every hour they are in class each week. This finding might imply that students do not make a deliberate and conscious effort, which is an essential part of applying study skills (Novak & Gowin, 1984). It also shows that students' planning does not have a purpose since according to Demir (2011, as cited in Demir, Kilink & Dogan, 2012, p. 427) setting the period for studying is characterized by focusing on studying courses at times close to the day and time of course-lectures.

Main implications and conclusion

Putting findings together, this survey has shown that Greeks were willing to self-assess their study skills use. Findings from the self-assessment questionnaires revealed that students are not properly trained to engage in study skills during their learning. Greek students' responses showed that their answers are not consistent since most of them (73.61%) reported that they were not confident employing study skills. The main thrust of information showed that most of the students rarely engage in intentional study behavior, rarely make use of their metacognitive knowledge on specific task and strategy variables and rarely make use of their metacognitive skill of evaluation. These findings might show that the students' task choices seem to be linked to self-efficacy beliefs and interest in the task which highlights the importance of initiating the learning process (Pintrich & De Groot, 1990). This means that students need to be persuaded of the importance of each learning goal in order to commit to its achievement (ibid).

These findings might be explained by the fact that in Greek primary and secondary education, there is no official training on study skills. Research in the Greek foreign language teaching context shows that even though lower secondary Greek pupils regard the teacher as a facilitator for EFL learning, they believe that that language success depends on their efforts even with limited language knowledge (Psaltou-Joyce & Sougari, 2010). The researchers found that Greek pupils welcome the idea of assuming responsibility for their learning but there needs to be a shift in focus to help them learn. It was suggested that pupils need training in order to monitor, edit and make an evaluative judgement about their output (ibid). This finding corroborates with findings by a survey conducted by Kassotakis and Verdis (2013) who found that Greek pupils attend frontistiria (private teaching centres) or individual courses at home mainly because they want to fill learning gaps owing to the shortcoming and weaknesses of the formal state school, for example many reported that they attend these centres or private courses in order to improve their study skills.

The main implication is that there is a need for more constructive discussion around the content of compulsory higher education in Greece. Even though it is not possible to design an instruction strategy based on the beliefs of each individual learner, it is possible to tailor language instruction to the needs of the majority of the learners. Therefore, instructional delivery should be the focus of an approach of skills training in Greek higher education by considering both the specific context of ESAP since Greek pupils at school study language as EFL and taking into account of students' perceptions reflecting which areas students need to be helped most (Psaltou-Joyce & Kantaridou, 2009). The results of the current study could be used in order to analyse further the identified students' weaknesses in study use by gathering qualitative data on students' specific sub-questions of each study skill. This further analysis could help to design an effective support learning environment that focuses on types of learning activities that are most likely to result in skill-oriented outcomes of appropriate study skill use (Allan and Clarke, 2007).

The author appreciates that there are some limitations with regard to the sample and the locality of the study that do not allow for generalization for all Greek students' use of study skills during learning in Greek universities. The sample is restricted to first year students studying ESAP at

the department of Business Administration of Food and Agricultural Enterprises, in university of Patras. Perhaps the attitudes and motivation of other older in year of attendance Greek students studying in other departments in university of Patras or other Greek universities might differ. Also, the current discussion of the study findings excludes any analysis of gender differences in terms of study use or assessment of students' study skills while studying for other subjects apart from ESAP. However, the size of the sample is sufficient for the findings to be used as a basis for similar studies in other departments or universities.

References

- Allan, J., & Clarke, K. (2007). Nurturing supportive learning environments in HE through the teaching of study skills: To embed or not to embed? *International Journal of Teaching and Learning in HE*, 19(1), 64-76.
- Benesch, S. (1996). Needs analysis and curriculum development in EAP: an example of a critical approach. *TESOL Quarterly*, 30(4), 723-738.
- Bowden, J., & Marton, F. (2000). *The university of learning*. London: Kogan Page
- Brindley, G. P. (1989). The role of needs analysis in adult ESL program design. In R. K. Johnson (Ed.), *The Second Language Curriculum*, (pp. 63-78). Cambridge: Cambridge University Press.
- Brown, A. L. (1978). Knowing when, where and how to remember: A problem of metacognition. In R. Glaser (Ed.), *Advances in instructional psychology* (pp. 77-165). New York: Halsted Press.
- Bowyer-Crane, C. and Snowling, M.J. (2005). Assessing children's inference generation: What do tests of reading comprehension measure? *British Journal of Educational Psychology*, 75(2), 189-201.
- Chostelidou, D. (2010). A needs analysis approach to ESP syllabus design in Greek tertiary education: A descriptive account of students' needs. *Procedia - Social and Behavioral Sciences*, 2, 4507-4512
- Credé, Marcus and Kuncel, Nathan R. (2008). Study Habits, Skills, and Attitudes: The Third Pillar Supporting Collegiate Academic Performance. *Perspectives on Psychological Science*, 3(6), 425-453.
- Cromley, J.G. & Azevedo, R. (2007). Testing and refining the direct and inferential mediation model of reading comprehension. *Journal of Educational Psychology*, 99, 311-325.
- Demir, S., Kilinc, M., & Dogan, A. (2012). The effect of curriculum for developing efficient studying skills on academic achievements and studying skills of learners. *International Electronic Journal of Elementary Education*, 4(3): 427-440.
- Desoete, A. (2008). Multi-method assessment of metacognitive skills in elementary school children: How you test is what you get. *Metacognition and Learning* 3, 189-206.
- Desoete, A., & Roeyers, H. (2002). Off-line metacognition – A domain-specific retardation in young children with learning disabilities. *Learning Disability Quarterly*, 25, 123-139.

- Entwistle, N. and Entwistle, D. (2003) Preparing for examinations: The interplay of memorising and understanding, and the development of knowledge objects. *Higher Education Research and Development*, 22 (1), 19-41.
- Entwistle, N. (2007) Research into student learning and university teaching, *Student Learning and University Teaching. British Journal of Educational Psychology Monograph Series 2* (4) 1-18.
- Entwistle, N. J., & McCune, V. (2009). The disposition to understand for oneself at university and beyond: learning processes, the will to learn and sensitivity to context. In L-F. Zang & R. J. Sternberg (Eds.), *Perspectives on the nature of intellectual styles* (pp. 29-62). New York: Springer.
- Eslami, Z. R. (2010). Teachers' voice vs. students' voice: a needs analysis approach to English for Academic Purposes (EAP) in Iran. *English Language Teaching*, 3(1), 3-11
- Felder, R., & Brent, R. (2005). Understanding student differences. *Journal of Engineering Education*, 94(1), 57-72.
- Flavell, J. H. (1979). Metacognition and cognitive monitoring: A new area of cognitive-developmental inquiry. *American Psychologist*, 34, 906-911.
- Flavell, J. H. (1987). Speculations about the nature and development of metacognition. In F. E. Weinert & R. H. Kluwe (Eds.), *Metacognition, motivation and understanding*, (pp. 21-29). Hillsdale, NJ: Erlbaum
- Gall, M.D., Gall, J.P., Jacobsen, D.R. & Bullock, T.R. (1990). *Tools for Learning. A Guide to Teaching Study Skills*. Alexandria, Virginia: Association for Supervision and Curriculum Development (ASCD)
- Geeslin, K. L. (2003). Student self-assessment in the foreign language classroom: The place of authentic assessment instruments in the Spanish language classroom. *Hispania*, 86 (4), 857-868.
- Gettinger, M., & Seibert, J. K. (2002). Contributions of study skills to academic competence. *School Psychology Review*, 31, 350-365.
- Glenn, R. E. (2003). Study skills to help kids use time wisely. *Education Digest*, 69(3), 51-53.
- Graesser, A.C., Singer, M., & Trabasso, T. (1994). Constructing inferences during narrative text comprehension. *Psychological Review*, 101, 371-395
- Hirschon, R. (2013). Cultural Mismatches: Greek Concepts of Time, Personal Identity, and Authority in the Context of Europe. In K. Featherstone (Ed.), *Europe in Modern Greek History*, (pp. 153-169). London: Hurst

- Holmes, J. & Celani, M.A.A. (2006). Sustainability and local knowledge: the case of the Brazilian ESP Project 1980-2005. *English for Specific Purposes*, 25(1), 109-122.
- Houtte, M. V. (2004). Why boys achieve less at school than girls: the difference between boys' and girls' academic culture. *Educational Studies*, 30(2), 159-173.
- Hutchinson, T., & Waters, A. (2002). *English for Specific Purposes*. Shanghai: Shanghai Foreign Language Education Press
- Johnson, R. B., & Onwuegbuzie, A. J. (2004). Mixed methods research: A research paradigm whose time has come. *Educational Researcher*, 33(7), 14-26.
- Jordan, R. R. (1997). *English for academic purposes, a guide and resource book for teachers*. Cambridge : Cambridge University Press
- Karagiannopoulou, E. (2007). *About learning. The relational facet of learning*. Athens: Gutenberg (in Greek)
- Kassotakis, M., & Verdis, A. (2013). Shadow education in Greece: Characteristics, consequences and eradication efforts. In Bray, M., Mazawi, A.E. & Sultana, R.G. (Eds.), *Private Tutoring across the Mediterranean: Power Dynamics and Implications for Learning and Equity* (pp.93-113). Rotterdam: Sense Publishers.
- Katsara, O. (2008a). The use of focus group interview in order to define students' views of the ESP course, *English for Specific Purposes World Journal*, 2(18), Vol. 7.
- Katsara, O. (2008b). Aspects of motivation within the context of an ESP course. *ESP World Journal*, 7(3), 1-26.
- Katsara, O. (2010). The development of a web-site for preparing Greek students for an ESP course. In E. Panourgia, T. Dalpanagioti, F. Perdiki, & M. Makrina (Eds.). *Proceedings of the 2nd ESP/EAP Conference: ESP/EAP Innovations in Tertiary Settings: Proposals and Implementations* (pp. 188-198). Kavala, Kavala Institute of Technology.
- Katsara, O. (2014). The need to investigate the Greek cultural perspective within the teaching practice of an ESAP class. *Asian ESP Journal*, 10(2), 88-113.
- Katsara, O. (2016). The role of the Greek tutor in tutorial sessions within an English for Specific Purposes context: An expert or a facilitator? In Rizomilioti, V. and V. Deli (Eds.). *Proceedings for English for Academic Purposes: Teaching Practices and Challenges*, (pp. 38-49), Foreign Languages Unit, University of Patras.
- Kedra, K., & Rotidi, G. (2017). University Pedagogy: A New Culture Emerging in Greek Higher Education. *International Journal of Higher Education*, 6(3), 147-153.
- Lakasas, A. (2008, July 20). Η αποστήθιση βασιλεύει και στα ΑΕΙ [Rote learning reigns in universities]. Η Καθημερινή. Retrieved from <http://news.kathimerini.gr>
- Langer, A. M. (2002). Reflecting on practice: using learning journals in higher education and continuing education. *Teaching in Higher Education*, 7(3), 337-351.

- Lucangeli, D., Cornoldi, C., & Tellarini, M. (1998). Metacognition and learning disabilities in mathematics. In T.E. Scruggs & M.A. Mastropieri (Eds.), *Advances in Learning and behavioral disabilities*, (pp. 219-285). Greenwich: JAI Press Inc.
- Marton, F. (1976). What Does It Take to Learn? Some Implications of an Alternative View of Learning. In N. J. Entwistle (Ed). *Strategies for Research and Development in Higher Education*, (pp. 32-43). Amsterdam: Swets and Zeitlinger
- Nelson, T. O. (1996). Consciousness and metacognition. *American Psychologist*, 51, 102-116.
- Novak, J. D., & Gowin, D. B. (1984). *Learning how to learn*. New York: Cambridge University Press.
- Oleson A, Hora M.T (2014). Teaching the way they were taught? Revisiting the sources of the teaching knowl- edge and the role of prior experience in shaping faculty teaching practice. *Higher Education*, 68(1): 29-45
- Özsoy, G., Memiş, A., ve Temur, T. (2009). Metacognition, Study Habits and Attitudes, *International Electronic Journal of Elementary Education*, 2(1), 154-166.
- Pintrich, P.R., & DeGroot, E.V. (1990). Motivational and self-regulated learning components of classroom academic performance. *Journal of Educational Psychology*, 82, 33-40.
- Polychronaki, M. (2004). Educational mobility and para-educational mechanisms. The perceptions of students and state school teachers concerning the role of frontistiria and idietera in transition from secondary to higher education. (Unpublished PhD dissertation). University of Crete, Rethymnon. Available at: http://elocus.lib.uoc.gr/dlib/f/7/f/metadata-dlib-2004_polychronaki.tkl [in Greek].
- Psaltou-Joycey, Angeliki and Zoe Kantaridou. 2009 Foreign language learning strategy profiles of university students in Greece. *Journal of Applied Linguistics*, 25, 107-127.
- Psaltou-Joycey, Angeliki and Areti-Maria Sougari. 2010. Greek young learners' perceptions about foreign language learning and teaching. In A. Psaltou-Joycey and M. Mattheoudaki (Eds), *Proceedings of the 14th International Conference of Applied Linguistics -Advances in research on language acquisition and teaching: Selected papers* (pp. 387-401). Greek Applied Linguistics Association: Thessaloniki.
- Purpura, J. & King, G. J. (2003). Investigating the Foreign Language: Needs of Professional School Students in International Affairs. *Working Papers in TESOL & Applied Linguistics*, 4 (1), 1-33.
- Rafoth, M. A. & DeFabo, L. (1990). *Study skills. What research says to the teacher?* West Haven, Connecticut: NEA Professional Library, ED 323 184.

- Sandelowski, M. (2000). Focus on Research Methods: Combining Qualitative and Quantitative Sampling, Data Collection, and Analysis Techniques in Mixed-Method Studies. *Research in Nursing & Health*, 23(3), 246-255.
- Sifakis, N. C. (2005). English for Specific and Academic Purposes – trendy demand? Orientations in ESP/EAP research, with a critical perspective on the Greek situation. In F. Perdiki; E. Panourgia; E. Vergidou; K. Samara (Eds.), *Proceedings for 1stESP Conference in Kavala – Teaching foreign languages for specific purposes: a trend or a demand?* pp. 17-30). Kavala: TEI of Kavala.
- Stronge, J. H., Ward, T. J., & Grant, L. W. (2011). What makes good teachers good? A cross-case analysis of the connection between teacher effectiveness and student achievement. *Journal of Teacher Education*, 62, 339–355.
- Tobias, S. & Everson, H.T. (1996). *Assessing metacognitive knowledge monitoring*. College Board Report No. 96-01. NY: The College Board
- VanDijk, T. A and Kintsch, W. (1983). *Strategies of discourse comprehension*. New York: Academic Press
- Ward, N., & Tatsukawa, H. (2003). A tool for taking class notes. *International human-computer studies*, 59, 959-981.
- Winne, P. H. (1997). Experimenting to bootstrap self-regulated learning. *Journal of Educational Psychology*, 89, 1-14.
- Yu, D.D. (2011). How Much Do Study Habits, Skills, and Attitudes Affect Student Performance in Introductory College Accounting Courses? *New Horizons in Education*, 59(3), 1-15
- Zahorik, J., Halbach, A., Ehrle, K., & Molnar, A. (2003). Teaching practices for smaller classes. *Educational Leadership*, 61(1), 75-77.
- Zimmerman, B. J., Bonner, S., & Kovach, R. (1996). *Developing self-regulated learners: Beyond achievement to self-efficacy*. Washington, DC: American Psychological Association

Appendix A

Studying	Rarely %	Sometimes %	Often %
I study where it is quiet and has few distractions	9.72	34.72	55.55
I study for a length of time then take a short break before returning to studying	20.83	34.72	43.83
I have all my supplies handy when I study, such as pens, paper, calculator, etc.	11.11	37.5	51.38
I set study goals, such as the number of problems I will do or pages I will read.	19.44	40.27	40.27
I study at least two hours for every hour I am in class each week.	34.72	34.72	30.55

Reading Text Books	Rarely %	Sometimes %	Often %
I browse the headings, pictures, charts, questions and summaries before reading a chapter.	20.83	50	29.16
I make questions from a chapter before, during, and after reading	44.44	40.27	15,27
I try to get the meaning of new words as I see them for the first time.	11.11	29.16	58.33
I look for familiar concepts as well as ideas that spark my interest as I read	13.88	56.94	47.61
I look for the main ideas as I read.	8.33	40.27	51.38

Taking notes	Rarely %	Sometimes %	Often %
I take notes as I read my text books	37.5	74.41	18.05
I take notes during class lectures	25	45.83	29.16
I rework, rewrite, or type up my notes	39.72	39.72	25
I compare my notes with a classmate	44.44	36.11	19.44
I try to organize main ideas and details into a meaningful method	5.5	47.22	47.22

Memorizing	Rarely %	Sometimes %	Often %
I try to study during my personal peak energy time to increase my concentration level.	23.61	22.22	54.16
I quiz myself over material that could appear on future exams and quizzes.	13.88	52.77	33.33
I say difficult concepts out loud in order to understand them better.	9.72	47.22	43.05
I summarize my notes into my own words, for better understanding	12.5	41.66	45.83
I try to create associations between new material I am trying to learn and information I already know	12.5	41.66	45.83

Managing time	Rarely %	Sometimes %	Often %
I use a planner (or other method) to write down upcoming academic and personal activities	8.33	54.16	37.5
I use a “to do” list to keep track of completing my academic and personal activities	8.33	44.44	47.22
I start studying for quizzes and tests at least several days before I take them	11.11	54.79	33.33
I start papers and projects as soon as they are assigned.	13.88	55.55	30.55
I have enough time for school and fun	13.88	55.55	30.55

Preparing for tests	Rarely %	Sometimes %	Often %
I study with a classmate or group	33.33	45.83	20.83
When I don't understand something, I get help from tutors, classmates, and my instructors	25	44.44	30.55
I do all homework assignments and turn them in on time.	12.5	38.88	48.61
I can easily identify what I have learned and what I have not yet learned before I take a test.	4.16	55.55	40.27
I anticipate what possible questions may be asked on my tests and make sure I know the answers	8.33	50	41.66

THE UNITED STATES AND BRITISH SOUTHEAST ASIAN POLICY 1950 – 1955

SAH-HADIYATAN ISMAIL

School of Distance Education, Universiti Sains Malaysia, Pulau Pinang, Malaysia

ABSTRACT

This article looks at the growing tension involving the Western powers with the Communist and the intensifying of the Cold War in the Asian region. The period of 1950 – 1955 temporarily shifted the attention of the United States from Europe to the Southeast Asian region. In contrast with European issues, Asian issues never entered deeply into the Anglo-American relationship until the Korean War. Britain seriously viewed the alarming situation in Asia as a threat to its economic interest and alerted the United States of the dangers of Communism in this area. Britain also hoped to secure the American commitment to the Southeast Asian area which was considered to be in the British sphere and for the overall defence of the free world. The period of 1950-1955 was also important to the Southeast Asia region because during this time important events that shaped the future of this region took place. International events such as the Korean War, the inauguration of the Colombo Plan, and the formation of SEATO, gave a big impact on the Anglo-American relations vis-à-vis the Southeast Asian region. The Anglo-American relations faced its trying times during this period as differences of approach started to arise. This article also focused on the difference of approaches between the US and Britain in their approaches to the containment of Communism in Southeast Asia. The Americans were more into military approach whereas the British were more interested in the economic aspect.

Keywords: US Foreign Policy, Communism, British Foreign Policy, Southeast Asia, Colombo Plan

QUALITATIVE EXAMINATION OF THE PERSPECTIVES OF PARENTS WITH GIFTED CHILDREN ON MATHEMATICS EDUCATION

SERDAL BALTACI

AVNI YILDIZ, CAHIT AYTEKIN

2 Asst. Prof. Dr., Bulent Ecevit University, Ereğli Faculty of Education,
Elementary Mathematics Education Department, Ereğli, Zonguldak, TURKEY

1,3 Assist. Prof. Dr., Ahi Evran University Faculty of Education,
Elementary Mathematics Education Department, Kırşehir, TURKEY

ABSTRACT

In this study, we compared the expectations of the gifted students' parents and other parents, who do not have a gifted child, from mathematics education based on parents' education levels, family incomes, and mathematics achievements. This study was designed as descriptive study, and a total of 293 parents participated, 126 of them were parents of gifted students and 167 of them were parents of non-gifted students, in the study. Parent Expectation from Mathematics Education Scale (PEME) developed by Aytekin et al. (2016) used in collecting the parents' expectations. When the findings of this study were examined, there was a significant difference between the two groups of parents' (parents who were not graduated from elementary school or graduated from elementary school category and graduated from high school category) expectations on the authority and rule-based teaching. It has been determined that the parents of gifted students had a lower level of authority and rule-based teaching expectations than the other parents without regarding the level of education. The results showed that the secondary school graduates parents who had gifted child had higher positive behaviors and attitudes expectations than other parents. Furthermore, the gifted students' parents, who declared moderate mathematics success, had significantly higher the conceptual understanding and active student expectations. On the other

hand, there was a significant difference between two groups of parents, whose monthly incomes were 751 dollars or above, on the authority and rule-based teaching expectations.

Keywords: Gifted Students' Parents, Middle School Students' Parents, Expectations from Mathematics Education

I. INTRODUCTION

Parents' awareness about mathematics increases the success of their children (Pezdek, Berry & Renno, 2002). Cai (2003) also found that there is a positive relationship between the level of family participation to education and mathematics achievement of the students. In addition, Booth and Dunn (1996) pointed out that positive attitudes and emotional development of the students whose family show active participation in the education process are getting better. On the other hand, it has been stated that parents' expectations strongly influence students' goals and expectations in the progressive education process (Chen & Fan, 2001; Davies, 1991).

It can be said that the quality of the education for gifted individuals plays an important role in the development of countries. For this reason, the importance of educating gifted individuals is increasing day by day. However, one thing to consider in this process is that, as Deur (2011) points out, the gifted students need more adult guidance than other students. Hence, the parents have important obligations in the education of gifted students who are very essential for the countries.

Gifted students in the mathematics are students who can demonstrate the mathematical skills that older ones can do (Sowell, Zeigler, Bergwell & Cartwright, 1990). But, there may be parents who are waiting for a meaningful teaching even if it takes time or they are just waiting for a teaching based on memorizing the rules and conducting them. Thus, solving problems quickly and memorizing symbols, numbers and formulas cannot be regarded as an indicator of giftedness (Wieczerkowski, Cropley & Prado, 2000).

Ecless and Harold (1993) classified the forms of participation of parents in education under five categories. In this classification, the first level parents were only the audience, and the fifth level parents, who are the highest level, were constantly communicating with teachers and school administration, spending extra effort for the development of their children, following their children's daily efforts, and their progresses. Similarly, Cai, Moyer, and Wang (1999) defined five different parent roles according to their contributions to their children's mathematics: motivational, audience, resource provider, supportive, and advisor. They stated that the parents in the supportive and advisor roles assist their children in their homes.

However, there is a lot of information in the literature describing the development and characteristics of gifted students, research on their parents, who have a large role in their

education, are limited. In this study, we compared the expectations of the gifted students' parents and other parents, who do not have a gifted child, from mathematics education based on parents' education levels, family incomes, and mathematics achievements. In this respect, it is possible to take an important step in the educational process by examining the expectations of parents who have gifted and non-gifted child. It is also thought that research will provide useful information to curriculum developers.

2. METHOD

In this section, information related to research design, sample, instruments and data analysis were given.

2.1 Research Design

The special case study method was used in designing this research because it is essential to examine a certain group in depth.

2.2. Sample

A total of 293 parents participated in the research in the academic year of 2017-2018, 126 of them were parents of gifted students and 167 of them were parents who have non-gifted students. The data on gifted student parents are collected from two different Science Arts Centers (SAC) institutions where gifted students are trained, while the data on non-gifted pupils are collected from two public middle schools.

2.3. Instruments

"Parent Expectation from Mathematics Education Scale (PEME)" developed by Aytekin and others (2016) used in the study. The three-factor structure of the scale was confirmed by confirmatory factor analysis. The factors of the scale are respectively "Conceptual Understanding and Student Active Engaging", "Expectation of Positive Behaviour and Attitude", "Authority and Rule-Based Teaching". In addition, it has been determined that the scale is a valid and reliable measurement tool.

2.4. Data Analysis

Data were analyzed using the SPSS 18.00 package program. In addition to descriptive statistics, inferential statistics such as independent samples t-test were also used in these analyzes.

3. RESULTS

When the expectations of two groups of parents were analyzed according to their educational levels, Table 1 was obtained.

Table 1. The independent samples t-test results for the expectations of gifted/non-gifted student parents' according to their education levels.

Education Levels			N	Mean	Std. Deviation	Mean Difference	Std. Error Difference	df	t	p
Elementary and Below	Conceptual Understanding and Active Student Expectation	gifted	33	21,6061	2,66856	1,14310	,72030	85	1,58	,116
		non-gifted	54	20,4630	3,56986					
	Positive Attitude and Behavior Expectation	gifted	33	21,6667	3,36031	,05556	,81631	85	,068	,946
		non-gifted	54	21,6111	3,88231					
	Authority and Rule-Oriented Teaching Expectation	gifted	33	15,3030	5,40535	-3,99327	1,05130	85	-3,79	,000
		non-gifted	54	19,2963	4,32033					
Middle School	Conceptual Understanding and Active Student Expectation	gifted	34	21,5882	2,52404	1,43606	,82670	78	1,73	,086
		non-gifted	46	20,1522	4,29970					
	Positive Attitude and Behavior Expectation	gifted	34	22,3235	2,63681	1,88875	,86264	78	2,19	,032
		non-gifted	46	20,4348	4,48530					
	Authority and Rule-Oriented Teaching Expectation	gifted	34	16,5882	5,08186	-1,32481	1,10082	78	-1,203	,232
		non-gifted	46	17,9130	4,70379					
High School	Conceptual Understanding and Active Student Expectation	gifted	41	20,7073	3,35592	-,95935	,66672	87	-1,439	,154
		non-gifted	48	21,6667	2,93427					
	Positive Attitude and Behavior Expectation	gifted	41	21,4146	3,09011	-,39787	,71999	87	-,553	,582
		non-gifted	48	21,8125	3,61825					
	Authority and Rule-Oriented Teaching Expectation	gifted	41	14,0732	5,17393	-5,11433	1,01248	87	-5,051	,000
		non-gifted	48	19,1875	4,37914					
University Level	Conceptual Understanding and Active Student Expectation	gifted	18	22,2222	3,00109	2,38012	1,14162	35	2,085	,044
		non-gifted	19	19,8421	3,86240					
	Positive Attitude and Behavior Expectation	gifted	18	21,7222	4,52191	1,45906	1,51781	35	,961	,343
		non-gifted	19	20,2632	4,70038					
	Authority and Rule-Oriented Teaching Expectation	gifted	18	16,8333	5,27201	-,90351	1,72637	35	-,523	,604
		non-gifted	19	17,7368	5,22645					

When the independent samples t-test results in Table 1 were examined, there is a significant difference between the two groups of parents' (parents who were not graduated from elementary school or graduated from elementary school category and

graduated from high school category) expectations on the authority and rule-based teaching. It has been determined that the parents of gifted students had a lower level of authority and rule-based teaching expectations than the other parents without regarding the level of education.

In Table 2, we compared two groups of parents' expectations according to their monthly incomes.

Table 2. The independent samples t-test results for the expectations of gifted/non-gifted student parents' according to their monthly incomes.

Monthly Incomes		N	Mean	Std. Deviation	Mean Difference	Std. Error Difference	df	t	p	
0-250 USD	Conceptual Understanding and Active Student Expectation	gifted	24	21,3333	3,29250	1,58824	1,25866	37	1,262	,215
		non-gifted	30	21,1000	3,19860					
	Positive Attitude and Behavior Expectation	gifted	24	21,8750	3,12511	1,66845	1,31900	37	1,265	,214
		non-gifted	30	22,6000	2,63400					
	Authority and Rule-Oriented Teaching Expectation	gifted	24	16,9167	5,79292	-4,39840	1,86401	37	-2,360	,024
		non-gifted	30	17,9667	5,00678					
251-500 USD	Conceptual Understanding and Active Student Expectation	gifted	59	21,4237	2,81133	,61604	,57022	135	1,080	,282
		non-gifted	78	20,8077	3,63267					
	Positive Attitude and Behavior Expectation	gifted	59	22,0000	3,21634	,74359	,62667	135	1,187	,237
		non-gifted	78	21,2564	3,91612					
	Authority and Rule-Oriented Teaching Expectation	gifted	59	15,7966	5,03703	-3,63929	,78560	135	-4,632	,000
		non-gifted	78	19,4359	4,15164					
501-750 USD	Conceptual Understanding and Active Student Expectation	gifted	26	21,2692	3,21941	,91788	,88379	61	1,039	,303
		non-gifted	37	20,3514	3,60722					
	Positive Attitude and Behavior Expectation	gifted	26	21,0385	3,74679	,57900	1,12751	61	,514	,609
		non-gifted	37	20,4595	4,81084					
	Authority and Rule-Oriented Teaching Expectation	gifted	26	14,5769	4,85941	-3,58524	1,13474	61	-3,160	,002
		non-gifted	37	18,1622	4,11308					
751 and over USD	Conceptual Understanding and Active Student Expectation	gifted	17	21,5882	2,59949	1,58824	1,25866	37	1,262	,215
		non-gifted	22	20,0000	4,64963					
	Positive Attitude and Behavior Expectation	gifted	17	21,9412	2,98895	1,66845	1,31900	37	1,265	,214
		non-gifted	22	20,2727	4,75276					
	Authority and Rule-Oriented Teaching Expectation	gifted	17	13,6471	5,70023	-4,39840	1,86401	37	-2,360	,024
		non-gifted	22	18,0455	5,82668					

The t-test results in Table 2 showed that it was found that the parents', whose income is 751 Dollars and above monthly, expectations from authority and rule-based teaching has a significant difference. Moreover, when the monthly income level of the parents increased, the "Authority and Rule-Oriented Teaching" expectations decreased.

In Table 3, we compared two groups of parents' expectations according to their success in mathematics.

Table 3. The independent samples t-test results for the expectations of gifted/non-gifted student parents' according to their success in mathematics.

Parents Success in Mathematics		N	Mean	Std. Deviation	Mean Difference	Std. Error Difference	df	t	p	
Low	Conceptual Understanding and Active Student Expectation	gifted	10	20,0000	2,49444	-1,73333	1,03186	23	-1,680	,107
		non-gifted	15	21,7333	2,54858					
	Positive Attitude and Behavior Expectation	gifted	10	21,6000	2,45855	-,53333	1,21026	23	-,441	,664
		non-gifted	15	22,1333	3,24844					
	Authority and Rule-Oriented Teaching Expectation	gifted	10	14,9000	4,20185	-4,56667	1,91227	23	-2,388	,026
		non-gifted	15	19,4667	4,96943					
Average	Conceptual Understanding and Active Student Expectation	gifted	50	21,3400	3,18549	1,38762	,65217	111	2,128	,036
		non-gifted	63	19,9524	3,63419					
	Positive Attitude and Behavior Expectation	gifted	50	21,5400	3,66567	1,41302	,77603	111	1,821	,071
		non-gifted	63	20,1270	4,40854					
	Authority and Rule-Oriented Teaching Expectation	gifted	50	16,6600	5,18479	-2,10190	,94147	111	-2,233	,028
		non-gifted	63	18,7619	4,79487					
High	Conceptual Understanding and Active Student Expectation	gifted	35	21,3143	2,74153	,76205	,75719	100	1,006	,317
		non-gifted	67	20,5522	4,01242					
	Positive Attitude and Behavior Expectation	gifted	35	22,0286	3,01453	,52111	,78859	100	,661	,510
		non-gifted	67	21,5075	4,12080					
	Authority and Rule-Oriented Teaching Expectation	gifted	35	14,3429	5,89588	-3,92580	1,01211	100	-3,879	,000
		non-gifted	67	18,2687	4,21607					

It was indicated that the expectations of the gifted students' parents, who declared moderate mathematics success, on the conceptual understanding and student active engaging is significantly high.

4. DISCUSSION

It has been determined that the parents of gifted students had a lower level of authority and rule-based teaching expectations than the other parents without regarding the level of education. Some studies have shown that the educational level of the parents does not play a role in the success of the students (Balli, Demo & Wedman, 1998). But, as noted by Kay, Fitzgerald, Paradee and Mellencamp (1994), low-educated parents may have more authoritarian and rule-based educational expectations. However, it is a reality that a rule-based education inhibits creativity and entrepreneurial skills (Kawamura, Frost & Harmatz, 2002).

Parents' own past mathematical success was found to be statistically significant on parental expectation types. It was found that the expectations of the gifted students' parents, who declared moderate mathematics success, on the conceptual understanding and student active engaging is significantly high. Pena (2000) concluded that families with high levels of education had higher contributions to their children's education and had more expectations for their schooling.

Mathematical activity that helps students experience leaps in understanding, or surprise, or that supports students to use their imagination is not typical in mathematics education (Gadanidis, Hughes & Cordy, 2011). Therefore, parents should help their students.

***Avni YILDIZ** is currently an assistant professor at the Department of Primary Mathematics Education. His research interests include teaching and learning of mathematics, technology integration in mathematics education especially focus on GeoGebra dynamic mathematics software, gifted students, problem solving and lesson study.*

***Serdal BALTACI** is currently an assistant professor at the Department of Primary Mathematics Education. His research interests include teaching and learning of mathematics, technology integration in mathematics education especially focus on GeoGebra dynamic mathematics software, gifted students, problem solving and lesson study.*

***Cahit AYTEKİN** is currently an assistant professor at the Department of Primary Mathematics Education. His research interests include mathematics and science integration, mathematics teacher training.*

References

- Aytekin, C., Baltacı, S., Altunkaya, B., Kıymaz, C., & Yıldız, A. (2016). A scale to determine parents' expectation from mathematics education (PEME): Development, reliability and validity. *Ahi Evran University Journal of Kırşehir Education Faculty (JKEF)*, 17(3), 397- 411.
- Balli, J. S., Demo, H. D., & Wedman, F. J. (1998). Family involvement with children's homework: An intervention in the middle grades. *Family Relations*, 47, 149-157.
- Booth, A., & Dunn, J. F. (1996). *Family-school links: How do they affect educational outcomes?*, Hillsdale, NJ: Erlbaum.
- Cai, J., Moyer, J. C., & Wang, N. (1999). Parental roles in students' learning of mathematics: An exploratory study. *Research in Middle Level Education Quarterly*, 22, 1-18.
- Cai, J. (2003). Investigating parental roles in students' learning of mathematics from a cross-national perspective. *Mathematics Education Research Journal*, 15(2), 87-106.
- Chen, M., & Fan, X. (2001). Parental involvement and students' academic achievement: A meta-analysis. *Educational Psychology Review*, 13, 1-22.
- Davies, D. (1991). Schools reaching out: Family, school and community partnership for student success. *Phi Delta Kapan*. 72(5), 376-382.
- Deur, P. V. (2011). Views of gifted elementary students about self-directed learning. *Gifted and Talented International*, 26:1-2, 111-120.
- Eccles, J. S., & Harold, R. D. (1993). Parent-school involvement during the early adolescent years. *Teachers College Record*, 94, 568-568.
- Gadanidis, G, Hughes, J., & Cordy, M. (2011). Mathematics for gifted students in an arts- and technology-rich setting. *Journal for the Education of the Gifted*, 34 (3), 397-433.
- Kawamura, K. Y., Frost, R. O., & Harmatz, M. G. (2002). The relationship of perceived parenting styles to perfectionism. *Personality and Individual Differences*, 32, 317-327.
- Kay, J. P., Fitzgerald, M., Paradee, C., & Mellencamp, A. (1994). Making homework work at home: The parent's perspective. *Journal of Learning Disabilities*, 27, 550-561.
- Pena, D. (2000). Parent involvement: Influencing factors and implications. *The Journal of Educational Research*, 94 (1), 42-54.
- Pezdek, K., Berry, T., & Renno, P. A. (2002). Children's mathematics achievement: The role of parents' perceptions and their involvement in homework. *Journal of Educational Psychology*, 94(4), 771-777.

Sowell, E. J., Zeigler, A. J., Bergwell, L., & Cartwright, R. M. (1990). Identification and description of mathematically gifted students: A review of empirical research. *Gifted Child Quarterly*, 34, 147-154.

Wieczerkowski, W., Cropley, A. J., & Prado, T. M. (2000). Nurturing talents/gifts in mathematics. In: Heller K. A.; Monks F. J.; Sternberg R. J.; Subotnik R. F. (Ed.). *International handbook of giftedness and talent education*. Oxford, United Kingdom: Pergamon, 2000. p. 413-425.

WEB-BASED SYSTEMS FOR SUPPORTING CHRONIC DISEASE SELF-MANAGEMENT

TEODORA DIMCHEVA
NONKA MATEVA, ANTONIA YANEVA, ZHIVKO PEYCHEV, KRISTINA KILOVA,
ANGELINA KIRKOVA-BOGDANOVA

Department of Medical informatics, Biostatistics and e-learning, Faculty of Public Health, Medical University-Plovdiv, Bulgaria

ABSTRACT

Long-term conditions and their concomitant management place considerable pressure on patients, communities, and health care systems worldwide. Information and telecommunication technologies are called to play a major role in the changes that healthcare systems have to face to cope with chronic disease. This paper discusses the capabilities of an interactive web-based platform that assists patients to self-manage their chronic disease. The focus is on motivating long-term behavior change. This is supported by an online assessment component based on the technique of motivational interviewing and a feedback component which visualizes actual behavior in relation to intended behavior. Disease-specific information is provided through an information portal that utilizes lightweight ontologies (associative networks) in combination with text mining. Emotional support is provided via virtual communities. The paper discusses the design rationales underlying the approach taken and outlines some implementational aspects.

Keywords: Self-management; web-based platform; chronic disease

METHODOLOGICAL PROBLEMS DETECTED IN TURKISH DIALECTICAL STUDIES

TUĞBA AYDIN YILDIZ

Lecturer, Bülent Ecevit University, Zonguldak, TURKEY

ABSTRACT

There have been many research studies about Turkish dialects in the recent years, but it seems that the methods used in these studies have been neglected. In order to develop new perspectives or create awareness, it is aimed to give necessary information and state a general view about the problems in the methodology of the Turkish dialects studies. Generally, this current study is a comprehensive literature review including past few decades, and has significant difference from the previous studies within a wide perspective of some important issues such as data collection tools, the technics, the evaluation of the results, the suggestions to the possible problems.

Keywords: Dialect, methodological problems

1. INTRODUCTION

The major concerns about the methodology are as in the follows:

-the technological developments are ignored while interacting people, transcription the interviews, recording the audial and visual data such as body language or facial expressions; and the suggested solution is to take the informational and technological developments serious, to determine a kind of common technics in order to fill the blanks of the methodological issues, to complete the content in the view of innovative improvements, to form an in-and-interdisciplinary association, to do the listening and the solution in the same environment at the same time (Öçalan, 2006),

-Synchronic and asynchronous data are analyzed and compared at the same time (the former should have the priority), and the suggestion is to balancing the samples and the explanation parts (i.e. to limit the amount of samples and the sufficient explanation), to focus on the origin of the language, more importantly, to accept that the dialect has the system in itself and should be analyzed separately (Demir, 2012)

-while processing the atlas of Turkish dialects, there are still insufficient evaluation criteria, and the suggestion is to determine common scales during the preparatory of the atlas (for example, settlement name, clan & family and tribe names, language features and etc.) and to determine how to analyze these data (Buran, 2010),

- The problems encountered during preparation of linguistic information in dialectical studies and the suggestion is to use more than one dictionary and to choose the most appropriate index (Akça, 2012),

- Problems faced in compilation, the subject of compilation, sampling and source identification, and the suggestion is to establish a certain standard in dialect studies (Akar, 2006).

2. THE HISTORY OF TURKISH DIALECT STUDIES

Dialect researches are challenging studies, such as compiling texts, deciphering compiled texts, tagging and reviewing texts, classifying dialect groups, preparing dictionaries or directories. The course of this chapter is to give general information about the history of Turkish dialect studies before facing the major methodological issues. The first study about the Turkish dialects is known to be examined by Maskinov (1867) and continued by J. Thury, I. Konoś, M. Hartmann,

K. Foy, V. Pisarev, L. Bonelli, F. Giese, F. Vincze (Korkmaz, 1995). However, the mentioned studies are very old and cannot go beyond history.

After the establishment of the Turkish Language Examination Society in 1932, problems related to Turkish dialects were introduced again. The first important work of the Language Association about the dialects has been the compilation of words that were not written into the Anatolian dialects. More than a 150.000 words compiled between 1933-1935 years, were published in The Journal of the People's Assembly during 1939-1949. However, most of the articulation and the meanings were not correct and the compilation is unscientific, so the Language Association revised and added 450.000 words and published a new version of the compilation in 1952, which laid the base of the Compilation Dictionary.

The first compilation dictionary which is the most frequently referred, was finished in 1979 and published in 1982 (Eren, 1990). On the other hand, the first text compilation was known to be collected by Ahmet Caferoğlu (in 1952, 1953, 1954a, 1954b). Zeynep Korkmaz published "The South-western Anatolian Dialects: Phonetics" in 1956 and it constitutes a turning point in Turkish dialect research. Furthermore, it has brought significant improvements into this field such as; correct selection of the references, transcription of signs in order to identify the correct formats and the comparative methods.

After this publication, many researchers and writers published local dialects of Turkish dialect until today (such as; Erzurum dialects by Kaya Bilgegil, Selahattin Olcay, Mehmet Kaplan; Kars dialects by Ahmet B. Ercilasun (1971), Artvin and Rize dialects by Turgut Günay (1972)). In later years, about Turkish dialects in Turkey, were researched from various aspects based on sound and structure classifications. "An Experimental Study on the Geographical Distribution of the Anatolian Dialects" of Japanese scientist Tooru Hayashi and Tahsin Banguoğlu's the classification of the Turkish Encyclopedia are the most distinctive studies that come to mind in this area (Karahan, 1996). The last classification study on Anatolian dialects was published by Leyla Karahan as "Anatolia Dialects Classification (Ankara-1996)".

3. LITERATURE REVIEW FOR MAJOR METHODOLOGICAL PROBLEMS IN TURKISH DIALECT STUDIES

In scientific studies, determining the method constitutes a very important phase of research. In this respect, it has become important to contact the method problems during the compilation, examination and research on dialect studies.

The Denomination Problem

"Anatolia and Rumeli" is the term used in dialect examinations in Turkey, however, it is not possible to accept this term because of its geographical limitation (because some countries like Cyprus, Iraq, and Syria has the same language developments). Therefore, Turkish dialects are required to include a denomination from a broader perspective.

Determining the Dialect Area

The compilations in dialect surveys usually take part in settlements where the dialect features are better protected such as villages and towns. In this context, the task of identifying the area to be investigated is a crucial problem. In order to overcome this problem, a historical, linguistic and sociological preliminary of the area should be examined in detail.

The Compilation Problems

Problems with compilation in dialect surveys are the most important method problems. During the compilation of the texts of the dialects, three elements, a) the compiler, b) the source, c) the material comes to the forefront.

In addition, the vocabulary and morphological differences label the studies as different texts from one another. Whether the texts are of a level that reflects the lexis of the research area is another question of compilations. Another important reason why the traditional narrative products (such as stories, tales) are disappearing is the change of oral tradition through the development of technology, but this is a separate research and review topic. In addition, basic vocabulary lists should be prepared to determine the language characteristics, pronunciation differences or synonyms. Basic words may include the organs, kinship, color and animal names; basic adjectives and verbs; numbers, pronouns and prepositions. The identification of source contacts (references) is another question in the compilations. The most important quality for the references is that s/he has not lost her/his dialect properties.

Marking Issue

One of the major problems is the difference in understandings of the dialect research on the marking. It is very important that the compiled texts are correctly solved and marked at the correct sound level. Because the main purpose of oral research is to determine phonetic differences.

Examination Method Problems

Another method problem in oral researches is which grammatical methods of compiled language material will be examined. The method of grammatical examination of the written language can also be applied to the dialect researches to provide a unity in this respect. Of course, it is necessary to be clear about the various methods involved. However, whichever method is applied, a common standard grammatical template is required which can be used by everyone.

Dialect-Ethnic Relationship Problem

Another problem is related to the ethnic structure of the dialects. The formation, the stratification and the relationships between the dialects, in Turkey, is a difficult area to require the diachronic study.

Information and Document Management Problem

Another problem in the dialect researches is the lack of information and document center related to this area which will carry out a central coordination and provide the information infrastructure to further studies.

Grammatical Index / Index term

The most commonly used directory is the grammatical array. All the words in a text can be defined as the whole alphabetical sequence, with the meanings and suffixes. The grammatical index prepares the knowledge features and the dictionary. At the same time, the grammatical indexes provide great convenience to the researcher in terms of easy access to a word or phrase found in the text.

Problems in Utilizing Information Technologies in Dialect Studies

Decoding of the sound and the creation of the text recordings are one of the most challenging stages. With digital audio recorders that have become popular in recent years, decryption can be done more easily thanks to these programs such as Adobe Audition which allows you to listen to the audio recordings in the digital environment by slowing it down in a computer environment, and allowing you to listen to a selected word repeatedly or showing the graphics of sounds.

4. CONCLUSION

As a result, there are various issues with the methodology used in Turkish dialect studies. Therefore, the aim of this current study is to identify these problems and to produce various solutions to shed light on the future dialect studies.

Tuğba Aydın Yıldız is a lecturer at the department of English Language and Literature for almost eight years. Her research interests include linguistics and English language, Turkish language, language acquisition, second language teaching.

References

- AKAR, Ali (2006). Ağız Araştırmalarında Yöntem Sorunları, *Turkish Studies* 1/2, 41- 53.
- AKCA, Hakan (2012). Ağız Çalışmalarında Gramatikal Dizin Hazırlarken Karşılaşılan Sorunlar. *Türkbilig*, 24, 121-142.
- BURAN, Ahmet (2010). Türkiye Türkçesi Ağız Atlasının Önündeki Sorunlar. *Diyalektolog*, 1, 15-20.
- CAFEROĞLU, Ahmet (1952). Erkilet Çerçilerinin Argosu ‘Dilce’, *Türk Dili ve Edebiyatı Dergisi*, IV/4, 334-344.
- CAFEROĞLU, Ahmet (1953). Anadolu Abdallarının Gizli Dillerinden Bir İki Örnek. *Fuad Köprülü Armağanı*, 77-79.
- CAFEROĞLU, Ahmet (1954a). Azerbaycan ve Anadolu Ağızlarında Moğolca Unsurlar, *TDAY*, 1-10.
- CAFEROĞLU, Ahmet (1954b). Pallacı, Tahtacı ve Çepni Dillerine Dair, *Türkiyat Mecmuası*, S. XI, 41-57.
- DEMİR, Nurettin (2012). Türkçe Ağız Araştırmalarında Bazı Yöntem Sorunları, *Diyalektolog*, 4, 1-8.
- ERCILASUN, B. Ahmet (1999). Türkçede Fiil ve Fiil Çekimi, *Türk Gramerinin Sorunları II*, Ankara: Türk Dil Kurumu Yayınları, 81-112.
- EREN, Hasan (1990). Sırça Köşkte, *Türk Dili*, Ocak-Şubat, 457- 458.
- KARAHAN, Leylâ (1996). Anadolu Ağızlarının Sınıflandırılması, *TDK Yayınları*, Ankara.
- KORKMAZ, Zeynep (1995). -sa / -se Dilek - Şart Kipi Eklerinde Bir Yapı Birliği Var Mıdır?. *Türk Dili Üzerine Araştırmalar I*, Ankara: Türk Dil Kurumu Yayınları, 160-167.
- ÖÇALAN, Muharrem (2006). Ağız Araştırmalarında Bilişim Teknolojilerinin Kullanılması ve Ağız Tezleri İçin Yenilik Önerileri. *Türklük Bilimi Araştırmaları “Tuncer Gülensoy Hatıra Sayısı”*, Ankara.

STUDENTS' SATISFACTION WITH E-SERVICES AT JERASH UNIVERSITY

YOUSEF ALJARAIDEH
AHMED RABEE

Associate Professors in Educational Technology, Department of Curriculum and Instruction,
Faculty of Educational Sciences, Jerash University

ABSTRACT

The purpose of this study is to investigate the students' satisfaction with e-services at Jerash University. A questionnaire was developed with (25) items to be procedurally divided into three domains: library resource, course delivery, online registration. The results of the study showed that the students' satisfaction toward university e-services was moderate. Statistically significant differences were also revealed in the students' satisfaction with e-services due to gender and year of study in favor of the male and first-year students respectively. In contrary, the results of the study showed no statistically significant differences in the students' satisfaction with e-services based on the type of faculty variable. Finally, the study recommended that updating the ICT infrastructure at Jerash University is highly essential in order to attract the students' attention to the teaching and learning process.

Keywords: Students' Satisfaction; E-services; E-library

1. Introduction

Currently, universities seek to provide e-services to their students in order to achieve the overall quality standards and qualify them for the labor market as highly depending on information and communication skills. Electronic services (or e-services) in higher education include various fields (e.g. library resource, course delivery, online registration) as important criteria in evaluating universities (Sutarso & Suharmadi, 2011). Therefore, universities should improve their electronic infrastructures in order to grab the attention of current/potential students for the teaching and learning process. In this context, Alshamayleh et al. (2015) indicated that the quality of e-services has a positive impact on student satisfaction. In the United Kingdom, the IT facilities were ranked in the first place among the e-services available at the universities; a student's use of e-services was for such educational purposes as the completion of assignments and preparation of lessons (Douglas, Douglas & Barnes, 2006).

Student satisfaction is defined as “the perception of enjoyment and accomplishment in the learning environment” (Sweeney & Ingram, 2001, p. 57). Another definition presented by Elliott and Shin (2002, p. 198) stresses that student satisfaction is “the favorability of a student's subjective evaluation of the various outcomes and experiences associated with education. [It] is being shaped continually by repeated experiences in campus life.” Before being used in the field of education, the term satisfaction has been still used in the fields of trade, industry and marketing. As a result of the increasing number of universities, there is a great competition among them to enroll more students; therefore, student satisfaction has become a highly important issue in higher education as students are the major targeted audience (Farahmandian, Minavand & Afshardost, 2013).

In the past ages, a teacher was considered as the main source of knowledge while his/her students were only passive learners. However, both teachers and students have been recently witnessed to jointly participate in delivering the content(s) of a university course. In actual fact, a teacher who is well-equipped with ICT competences is of a greater and more positive attitude toward ICT integration in classroom sittings; he/she is more capable of providing the students with sufficient opportunities that are necessary for improving their learning quality (Ghavifekr et al., 2014). Therefore, to improve student satisfaction by making e-services available will facilitate the teachers' task(s) and, accordingly, increase the number of students enrolled in a university.

No doubts, facilities like sport center, transportation, labs and eservices effect students' satisfaction toward their universities. Manzoor (2013) indicated that sport and transportation facilities have a great impact on satisfaction of students in universities. So that, universities should improve their facilities as well as update eservices infrastructure continually. Abbasi et al., (2011) conducted a study dealt with satisfaction of students in Pakistani universities, the results showed that students dissatisfied with facilities which provided by universities. More specifically students were dissatisfied with management support (e.g. registration department), computer lab, teaching and library. It concludes that the low service provided by the university leads to dissatisfaction by students and vice versa.

2. Problem Statement

This study aims at investigating the extent to which the students at Jerash University (JPU) are satisfied with the available e-services. JPU is the first private university in the Northern Province of Jordan. With four other universities to have been established so far, a real spirit of competition is being witnessed. Hence, to evaluate student satisfaction is today a considerable procedure as student enrollment has been less due to official decisions as to higher education and financial recourses are more complicated to procure (cf. Li et al., 2005). However, e-services and ICT infrastructures have been developing at JPU. In specific, classrooms are being equipped with computers hooked to the Internet, data-show apparatuses and smart boards. Many courses such as the blended or online ones delivered by new technology(s). The registration process—e.g. to add and/or withdraw courses—can be also effectively performed through the university's e-portal. With the goal to examine the JPU students' satisfaction with e-library resources, classroom technology and online registration, this study attempts the following two research questions:

To what extent are the students at JPU satisfied with the available e-services?

Are there any statistically significant differences in the students' satisfaction with e-services due to gender, studyyear and type of faculty?

3. Related Literature

E-library resources help students find out relevant journals, articles and books easily in comparison with the conventional methods. Gakibayo, Odongo and Obura (2013) indicated that students use electronic resources for internet searching, email, e-journal and e-book. Moreover,

around (30%) of the subject participants were found to utilize e-library resources from one to five times a week. Holley and Powell (2004) also aimed to identify student satisfaction with e-library resources; their respondents were randomly chosen from Wayne State University. The results of the study revealed that (68%) of the sample were satisfied with the e-services made available in the library.

Kara, Tanui and Kalai (2016) conducted a study to find out the relationship between the quality of academic resources and students' satisfaction. To achieve the objectives of the study, a questionnaire was developed and distributed to a number of (1062) students who were randomly chosen from public universities in Kenya. The results of the study showed a positive relationship between students' satisfaction from the one hand and teaching facilities, e-library services from the other hand. In Philippines, Secreto and Pamulaklakin (2015) conducted a study to assess students' satisfaction with services provided on university portals such as online registration and fees payment. The results showed that (85%) of the participants were satisfied with the e-services available on their university websites.

Rhema, Miliszewska and Sztendur (2013) conducted a study about student satisfaction with technology at the Libyan University. The study attempted to identify whether the students are satisfied with the technologies provided by their university. Such technologies were ICT infrastructures, Internet access and quality of integrated technology in classroom settings. The results of the study showed low levels of satisfaction with the existing technologies at the university. Delivering content by using a new technology could improve the students' computer skills and, hence, achieve the desired educational goals. In this context, Makura (2014) stated that the students in South Africa University are satisfied with the integrating technology for academic purposes. They believe that utilizing a new technology in the teaching/learning process would ensure their academic success and improve their computer skills.

A student's satisfaction with technology in the classroom is influenced by a set of factors such as flexibility, modernity, accessibility and stability (Ausburn, 2004; El Mansour & Mupinga, 2007). Previous computer skills, interaction between students and lecturers and revising the course content in the light of assessments are other factors reported by Mason & Weller (2000). To meet the students' satisfaction at universities should pay more attention to the services offered and resources made available. Gruber et al. (2010) also stated that a traditional university heavily concentrates on research and the teaching/learning process paying

no attention to the e-services provided to the students. These services contribute in boosting the satisfaction of the current students as well as attracting new potential ones.

Harvey, Parahoo and Santally (2017) indicated that no significant difference existed in online teaching due to gender. They also pointed out that certain factors could affect students' satisfaction with online courses such as physical facilities. In contrary, Uka (2014) reported that males were more satisfied with the services offered by the university compared to females; however, no significant differences were found in the services provided by the university due to age as the undergraduate and master's students had the same degree of satisfaction with those services. Moreover, the study revealed that there was no difference in the students' level of satisfaction with the university services based on type of faculty. Grebennikov and Skaines (2009) also stated that female students were more demanding about university services than males. In contrary, Butt and Rehman (2010) conducted a study to evaluate students' satisfaction in higher education. They found that female students were less satisfied with their education—such as learning environment and classroom facilities—than their male counterparts.

4. Method

A questionnaire was developed to assess the students' satisfaction with e-services at JPU based on the related literature and, in particular, such related studies as Bolliger & Erichsen (2013) University of Newcastle survey, 2008, Kazakhstan institute of management, economics and strategic research, 2011. The questionnaire was divided into three domains: e-library resources, classroom technology and online registration. The researchers distributed the questionnaire to the students of JPU in the first semester of the academic year 2016/2017. The data sets were collected and analyzed by using the Statistical Package of Social Sciences (SPSS). The instrumental validity was verified by presenting the preliminary form of the questionnaire to a number of faculty members in Jordanian universities specializing in educational technology, curriculum and instruction and assessment and evaluation. In the light of the opinions, comments and suggestions of those members, some items were amended and some others were deleted; new items were also added. Eventually, the final version of the questionnaire came up with twenty five (25) items.

For the issue of reliability, it was examined by applying the questionnaire on twenty (20) students from the population of the study yet out of the main sample. The questionnaire was reapplied two weeks later and the Pearson correlation coefficient calculated between the two applications was (0.90). This value was considered to be appropriate for the purposes of the present study.

Table 1: Distribution of the Participants According to Gender and Study Year

Gender	F	%
Female	239	51.96
Male	221	48.04
Total	460	100.0
Study Year	F	%
First	73	15.87
Second	142	30.87
Third	101	21.96
Fourth	144	31.30
Total	460	100.0
Type of Faculty	F	%
Humanities	261	56.74
Science	199	43.26
Total	460	100.0

5. Results and Discussion

5.1 Results related to Question 1: "To what extent are the students at JPU satisfied with the available e-services?"

To answer the first question of the study, the means and standard deviations of the students' satisfaction with the e-services made available at JPU were computed as presented in Table 2 below:

Table 2: Means and Standard Deviations of the JPU Students' Satisfaction with e-Services, Ranked in a Descending Order

Rank	N	Domain	Mean	Std. Deviation
1	2	Registration	3.38	.942
2	3	Content	3.38	.778
3	1	Library	2.97	.826
		Total Score	3.23	.705

Based on Table 2, the registration and content domains were found to receive the highest mean (3.38) regarding the degree of satisfaction while the library domain was ranked last with a mean of (2.97). This table also shows that the total mean is (3.65). The mean and standard deviation of each item in each domain were also calculated as shown in the following tables.

5.1.1 Library Domain

Table 3: Means and Standard Deviations of Library Items, Ranked in a Descending Order

Rank	N	Item	Mean	Std. Deviation
1	1	The Library website is easy to use.	3.31	1.000
2	6	The Library website provides useful information.	3.22	1.227
3	7	Online resources (e.g. e-journals, databases, e-books) meet my learning and research needs.)	3.11	1.118
4	3	Online enquiry services (e.g. ASAP, Ask a Question) meet my needs.	2.97	1.204
5	5	A computer is available when I need one.	2.96	1.328
6	2	Self Service (e.g. self-check loans, requests, renewals and holds) meets my needs.	2.95	1.098
7	4	Laptop facilities (e.g. desks, power) in the Library meet my needs.	2.87	1.255
8	8	Printing, scanning and photocopying facilities in the Library meet my needs.	2.71	1.264
9	9	When I am away from campus, I can access the Library resources and services I need.	2.65	1.276
		Library	2.97	.826

Table 3 shows that Item no. 1 “The Library website is easy to use” received the highest mean (3.31) regarding the degree of satisfaction. However, Item no. 9 “When I am away from campus, I can access the Library resources and services I need”) was ranked to be last with a mean of (2.65). The above table also shows that the mean of the Library domain as a whole was (2.97). The results of this research questionnaire almost in consistency with such previous studies as Gakibayo, Odongo & Obura (2013), and Holley & Powell (2004); such studies had already indicated to a moderate degree of student satisfaction with e-library services.

5.1.2 Registration Domain

Table 4: Means and Standard Deviations of Registration Items, Ranked in a Descending Order

Rank	N	Item	Mean	Std. Deviation
1	11	Web-accessible student information (payment report, grades, individual schedule, etc.) is complete and up-to-date.	3.94	1.158
2	10	On-line registration is clear and user friendly.	3.79	1.294
3	12	Printed information materials (newsletters, registration package, schedules, information board notes, etc.) are complete and up-to-date,	3.40	1.101
4	14	Registration process outside university meets my needs.	3.31	1.408
5	15	Registration Lab assistants are friendly and technical advice is helpful.	3.09	1.385
6	16	Registration facilities meet my interests.	3.07	1.320
7	13	Registrar assistance (transcript orders, registration for courses, graduation requirements, verification of the documents, etc.) is well-organized.	3.06	1.173
		Registration	3.38	.942

Table 4 shows that Item no. 11 “Web-accessible student information (payment report, grades, individual schedule, etc.) is complete and up-to-date”) received the highest mean (3.94) regarding the degree of satisfaction. However, Item no. 13 “Registrar assistance (transcript orders, registration for courses, graduation requirements, verification of the documents, etc.) is well-organized” was ranked to be last with a mean of (3.06). The above table also shows that the mean of the Registration domain as a whole was (3.38). The results of this research question in line with the results of such previous studies as Secreto & Pamulaklakin (2015) whereas they are in contrary with the results of Abbasi et al., (2011).

5.1.3 Content Domain

Table 5: Means and Standard Deviations of Content Items, Ranked in a Descending Order

Rank	N	Item	Mean	Std. Deviation
1	22	Compared to other course delivery methods, I am satisfied with this learning experience.	3.59	1.082
2	19	I am satisfied with the frequency I have to attend class (e.g., log into the course, participate).	3.55	.996
3	21	I am satisfied with the level of self-directedness required of me.	3.53	1.010
4	25	The assessment/grades in this course were clear and fair.	3.45	1.173
5	20	I am satisfied with the flexibility this course delivery method affords me.	3.33	1.089
5	24	I am satisfied with the quality of technology in delivering course content.	3.33	1.167
7	23	My level of satisfaction in this course would encourage me to enroll in another course that is delivered in this way.	3.32	1.266
8	18	I am satisfied with how I am able to navigate within the course management system.	3.23	1.121
9	17	I am satisfied with the use of “threaded” online discussions and/or forums.	3.10	1.227
		Content	3.38	.778

Table 5 shows that Item no. 22 “Compared to other course delivery methods, I am satisfied with this learning experience” received the highest mean (3.59) regarding the degree of satisfaction. However, Item no. 17 “I am satisfied with the use of “threaded” online discussions and/or forums” was ranked to be last with a mean of (3.10). The table above also shows that the mean of the Content domain as a whole was (3.38). The results of this research question were in consistency with the results of such previous studies as Makura (2014) and Douglas, Douglas & Barnes (2006).

5.2 Results related to Question 2: “Are there any statistically significant differences in the students’ satisfaction with e-services due to gender, study year and type of faculty?”

To answer the second question of the study, the means and standard deviations of the JPU students’ satisfaction with e-services due to gender, study year and type of faculty type were computed as presented in Table 6.

Table 6: Means, Standard Deviations of Students' Responses due to Gender, Study Year and Type of Faculty

Aspect		Mean	Std. Deviation	N
Type of Faculty	Humanities	3.22	.731	261
	Sciences	3.24	.670	199
Study Year	First	3.44	.780	73
	Second	3.19	.690	142
	Third	3.25	.642	101
	Fourth	3.16	.707	144
Gender	Male	3.29	.655	221
	Female	3.18	.745	239

Table 6 above shows a slight variance in the students' responses due to gender, study year and type of faculty.

5.2.1 Three-way ANOVA

To find out whether there were statistically significant differences in these means, a three-way ANOVA analysis was conducted and the results are shown in Table 7 below.

Table 7: Three-way ANOVA Results of Students' Responses due to Gender, Study Year and Type of Faculty

Source	Sum of Squares	Df	Mean Square	F	Sig.
Type of Faculty	.536	1	.536	1.105	.294
Study Year	6.429	3	2.143	4.419	.004
Gender	2.232	1	2.232	4.604	.032
Error	220.144	454	.485		
Corrected Total	227.844	459			

Table 7 above shows that:

1. There were no statistically significant differences at ($\alpha=0.05$) due to type of faculty. In line with Uka (2014), this particular result might refer to that the subject students from both scientific and human majors had experienced the same e-services offered by JPU.

2. In addition, the Table above shows that there were also statistically significant differences at ($\alpha=0.05$) due to gender in favor of males. This result might refer to that the male students had spent more time inside the university campus than the female ones. Also, the nature of the male students (e.g. curiosity and spirit of adventure) would help them experience as many services and/or facilities as possible. In relation to previous studies, the results of this research question were found to be:

- in consistency with Butt and Rehman (2010) and Uka (2014), but
- in contradiction with Grebennikov and Skaines (2009).

3. Moreover, the table above shows that there were statistically significant differences at ($\alpha=0.05$) due to study year. A post hoc analysis for multiple comparisons using the LSD method was calculated as provided in Table 9.

5.2.2 Multiple Comparisons

Various methods have been developed for doing multiple comparisons of group means. In SPSS, one way to accomplish the same is via the use of the post-hoc parameter. Table 8 illustrates what the different parts mean.

Table 8: Post Hoc Results for Multiple Comparisons Using LSD Method

		Mean Difference		
(I) Year	(J) Year	(I-J)	Std. Error	Sig.
First	Second	.26(*)	.101	.011
	Third	.20	.108	.066
	Fourth	.28(*)	.101	.005
Second	Third	-.06	.091	.509
	Fourth	.02	.083	.780
Third	Fourth	.08	.091	.359

Table 8 shows there were statistically significant differences at ($\alpha=0.05$) between the first- and second-year students in favor of the first-year ones. The differences were also encountered between the first- and fourth-year students in favor of the first-year ones. This particular findings entails that the first-year students did not have sufficient experiences with their university e-services and/or their satisfaction with the available e-services at JPU was based on their first impression. On the contrary, the fourth-year students who had already experienced most of their university e-services were found to reflect a degree of realistic satisfaction based on their experience. On this specific aspect, the result of this research question agree with such previous studies as Uka (2014).

6. Conclusion and Recommendations

Facilities like sport centers, transports, labs and e-services undoubtedly affect students' satisfaction toward their universities. Well-planned sport and transport facilities for instance could have a great impact on satisfaction. Therefore, universities should improve their important facilities as well as update their e-service infrastructures on a continual basis. The students at JPU could be also dissatisfied with such managerial supports as registration services, computer laboratories, teaching methods and library resources. In actual fact, the low service provided by a university should lead to dissatisfaction on the students' part and vice versa. Therefore, the study provides a relevant set of recommendations in this respect as follows:

- a) Updating the ICT infrastructure at JPU in order to attract the students' attention to its teaching/learning process.
- b) Conducting further studies in relation to the notion of student satisfaction to address other areas such as transports, facilities and administrative affairs.
- c) Paying more attention to any gender differences as the number of females is more than the males in some universities.

References

- Abbasi et al. (2011). A Study on student satisfaction in Pakistani Universities: The case of Bahauddin Zakariya University, Pakistan. *Asian Social Science*, 7(7), 209-219.
- Alshamayleh, H., Aljaafreh, R., Aljaafreh, A., & Albadayneh, D. (2015). Measuring the quality of e-service and its impact on student satisfaction at Jordanian university. *Journal of Theoretical and Applied Information Technology*, 74(3), 274-285.
- Ausburn, L. J. (2004). Course design elements most valued by adult learners in blended online education environments: An American perspective. *Educational Media International*, 41(4), 327-337.
- Bolliger, D., & Erichsen, E. (2013). Students satisfaction with blended and online courses based on personality type. *Canadian Journal of Learning and Technology*, 39(1), 1-23.
- Butt, B., & Rehman, K. (2010). A study examining student satisfaction in higher education. *Procedia Social and Behavioral Sciences* 2 (2010), 5446-5450.
- Douglas, J., Douglas, A., & Barnes, B. (2006). Measuring student satisfaction at a UK university. *Quality Assurance in Education*, 14 (3), 251-267.
- Elliott, K., & Shin, D. (2002). Student satisfaction: an alternative approach to assessing this important concept. *Journal of Higher Education Policy and Management*, 24(2), 197-209.
- El Mansour, B., & Mupinga, D. M. (2007). Students' positive and negative experiences in hybrid and online classes. *College Student Journal*, 41(1), 242-248.
- Farahmandian, S., Minavand, H., & Afshardost, M. (2013). Perceived service quality and student satisfaction in higher education. *Journal of Business and Management*, 12(4), 65-74.
- Gakibayo, A., Odongo, J., & Obura, C. (2013). Electronic information resource utilization by students in Mbarara university library. *Library Philosophy and Practice (e-journal)*. 869.
- Ghavifekr, S., AbdRazak, A., Ghani, M., Ran, N., Meixi, Y., & Tengyue, Z. (2014). ICT integration in education: Incorporation for teaching & learning improvement. *The Malaysian Online Journal of Educational Technology*, 2(2), 24-45.
- Grebennikov, L., & Skaines, I. (2009). Gender and higher education experience: a case study. *Higher Education Research & Development*, 28(1), 71-84.
- Gruber, T., Fuß, S., Voss, R., & Gläser-Zikuda, M. (2010). Examining student satisfaction with higher education services: Using a new measurement tool. *The International Journal of Public Sector Management*, 23, 105-123.
- Harvey, H., Parahoo, S., & Santally, M. (2017). Should gender differences be considered when assessing student satisfaction in the online learning environment for Millennials? *Higher Education Quarterly*, 71(2), 141-158.
- Holley, R., & Powell, R. (2004). Student satisfaction with electronic library resources at Wayne State University. *Journal of Access Services*, 2(1).
- Kara, A., Tanui, E., & Kalai, J. (2016). Quality of academic resources and students' satisfaction in public universities in Kenya. *Teaching and Educational Research*, 15(10), 130-146.
- Kazakhstan Institute of Management, Economics and Strategic Research. (2011). Student Satisfaction Survey REPORT, Department of Quality Assurance and Institutional Research.

- Li, Y., McCoy, E., Shelly, M. C., & Whalen, D. F. (2005). Contributions to student satisfaction with special program (Fresh Start) residence halls. *Journal of College Student Development*, 46, 176-192.
- Makura, A. (2014). Students' perceptions of the use of ICT in a higher education teaching and learning context: The case of a South African University. *Mediterranean Journal of Social Sciences*, 5(11), 43-47.
- Mason, R., & Weller, M. (2000). Factors affecting students' satisfaction on a web course. *Australian Journal of Educational Technology*, 16(2), 173-200.
- Rhema, A., Miliszewska, I., & Sztendur, E. (2013). Attitudes towards e-Learning and Satisfaction with Technology among Engineering Students and Instructors in Libya. *Proceedings of Informing Science & IT Education Conference (InSITE) 2013*.
- Manzoor, H. (2013). Measuring student satisfaction in public and private universities in Pakistan. *Global Journal of Management and Business Research Interdisciplinary*, 13(3), 5-16.
- Secreto, P & Pamulaklakin, R. (2015). Learners' satisfaction level with online student portal as a support system in an open and distance elearning environment (ODEL). *Turkish Online Journal of Distance Education*, 16(3), 33-47.
- Sutarso, Y., & Suharmadi, A. (2011). Promotion of e-technology-based services: A case study of e-service quality at a University in Indonesia. *International Journal of Business and Information*, 6(1), 112-133.
- Sweeney, J.C., & Ingram, D. (2001). A Comparison of traditional and web-based tutorials in marketing education: An exploratory study. *Journal of Marketing Education*, 23(1), 55-62.
- Uka, A. (2014). Student satisfaction as an indicator of quality in higher education. *Journal of Education and Instructional Studies in the World*, 4(3), 6-10.
- University of Newcastle survey Australia. (2008). Library customer satisfaction survey. Insync Surveys Pty Ltd

ANALYSIS OF THE EVALUATION OF MENTORS AND STUDENTS OF THE PHARMACY FACULTY IN THE CITY OF PLOVDIV (BULGARIA) FOR THE PRE-TRAINING IN PHARMACY

ZHIVKO PEYCHEV

NONKA MATEVA, TEODORA DIMCHEVA, KRISTINA KILOVA, ANTONIA YANEVA,
ANGELINA KIRKOVA, STELA PEYCHEVA*

Department of Medical informatics, Biostatistics and e-learning, Faculty of Public Health, Medical University-Plovdiv, Bulgaria

*Medical University – Plovdiv, Bulgaria, Faculty of Dental Medicine, Department of Pediatric Dental Medicine

ABSTRACT

Introduction: The six-month pre-graduate traineeship (6-MPT) of Master Pharma students in Bulgaria is a compulsory and integral part of their curriculum. The internship includes 960 hours, which are used to improve the ability to work at a pharmacy. Students have the opportunity to choose where to do their internship - at a public pharmacy or in a hospital pharmacy. Each trainee has two mentors. The first mentor-pharmacist monitors the practitioner's practical experience in the pharmacy, and the second is an academic lecturer who links the internship to the academic education and controls its conduct in accordance with the curriculum and state requirements.

AIM: The aim of the study is to analyze the opinion of the students and their mentors about the quality of the 6-MPT.

MATERIAL AND METHODS. The study was conducted among 112 students (58 Bulgarians and 54 foreign students) from the Faculty of Pharmacy of the Medical University of Plovdiv, 9 academic faculty lecturers from the same faculty and 38 mentoring pharmacists participating in the 6-MPT in 2016. A questionnaire was used - two specialized questionnaires were developed separately for students (35 questions) and for mentors (23 questions). To process feedback from

students and mentors we used statistical software SPSS V19.0. The survey covered 21 pharmacies in the city of Plovdiv and another 6 in the Plovdiv area, where 6-MPT were held.

RESULTS: A large number of the trainees 75 (67%) held their 6-MPT in Plovdiv. Most of them say they have performed 50 to 200 prescriptions and have served from 50 to 200 patients a day. 67 (59.8%) of trainees said that most pharmacies had a special sector for selling cosmetics. During the 6-MPT 42 (37.5%) trainees were selling drugs and cosmetics. Almost all trainees (105 (93.75%)) stated that during the traineeship, they were conducting pharmaceutical customer consultations on a daily basis and had pharmaceutical care for patients with chronic diabetes, arterial hypertension, cerebrovascular disease and others. 77 (68.7%) of survey participants stated that internship was very well organized and encouraged them to work as pharmacists. 24 (21%) of the trainees say they do not feel competent enough in the administrative work, and 25 (22%) of them say they do not have enough knowledge in many activities. Most of the 91 (81%) students state that if they wish they can start working at a pharmacy and 83 (74%) have already received a job as pharmacists. 33 (86.8%) of the mentor-pharmacists are managers of open-type pharmacies and the rest are managers of hospital pharmacies. The average assessment of the six-point system that mentors give to trainees is very good - 5.05.

CONCLUSION: The results of the statistical survey among trainees and mentors from the Faculty of Pharmacy of the Medical University of Plovdiv for the pre-graduate traineeship at the pharmacy show that the participants are satisfied with the practical aspects of the 6-MPT. Data analysis among trainees shows that internship is important and the experience gained very good. However, some of them say that they do not feel well prepared to carry out self-organization and administrative work at a pharmacy.

Keywords: Pre-graduate traineeship, pharmacy

WEI

**VIENNA,
AUSTRIA,
APRIL 17-19,
2018**

EDUCATION & HUMANITIES

BY THE WEI ISSN 2167-3179 (ONLINE) USA